

BLACK DIAMOND SCHOOL OF ENGINEERING,  
JHARSUGUDA

**STUDY MATERIAL**

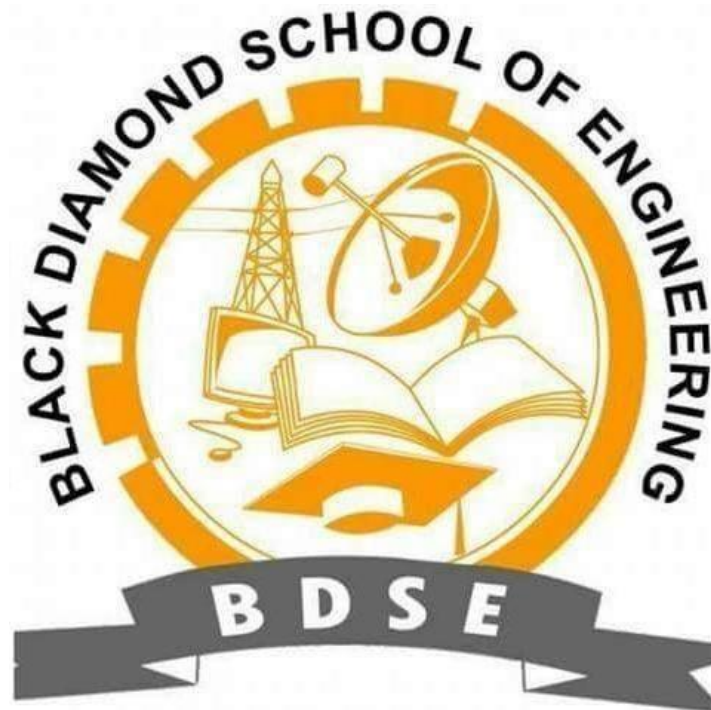

ON

**STRUCTURAL DESIGN-I (TH-1)**  
**FOURTH SEMESTER CIVIL ENGINEERING**

PREPARED BY

Mrs Tusarika Behera

Lecturer in Civil

Civil Engg Department

# CONTENT

<b>Chapter No.</b>	<b>Topic Name</b>	<b>Page No.</b>
2	Working Stress Method of Design	5 to 14
3	Philosophy of Limit State Method (LSM) of Design	15 to 20
4	Analysis and design of Singly and doubly Reinforced Members )	21 to 28
5	Shear,Bond, Development Length	44 to 59
6	Analysis and design of T- Beam in Limit State Method	60 to 76
7	Analysis and design of Slabs and stair case Limit State Method	77 to 95
8	Design of Axially Loaded short columns and footing(LSM)	96 to 111

## CHAPTER-1 WORKING STRESS METHOD OF DESIGN

### 2.1 General Concept

Working stress method is based on the behavior of a section under the load expected to be encountered by it during its service period. The strength of concrete in the tension zone of the member is neglected although the concrete does have some strength for direct tension and flexural tension (tension due to bending). The material both concrete and steel, are assumed to behave perfectly elastically, i.e., stress is proportional to strain. The distribution of strain across a section is assumed to be linear. The section that are plane before bending remain plane after bending. Thus, the strain, hence stress at any point is proportional to the distance of the point from the neutral axis. With this a triangular stress distribution in concrete is obtained, ranging from zero at neutral axis to a maximum at the compressive face of the section. It is further assumed in this method that there is perfect bond between the steel and the surrounding concrete, the strains in both materials at that point are same and hence the ratio of stresses in steel and concrete will be the same as the ratio of elastic moduli of steel and concrete. This ratio being known as ‘modular ratio’, the method is also called ‘Modular Ratio Method’.

In this method, external forces and moments are assumed to be resisted by the internal compressive forces developed in concrete and tensile resistive forces in steel and the internal resistive couple due to the above two forces, in concrete acting through the centroid of triangular distribution of the compressive stresses and in steel acting at the centroid of tensile reinforcement. The distance between the lines of action of resultant resistive forces is known as ‘Lever arm’.

Moments and forces acting on the structure are computed from the service loads. The section of the component member is proportioned to resist these moments and forces such that the maximum stresses developed in materials are restricted to a fraction of their true strengths. The factors of safety used in getting maximum permissible stresses are as follows:

<i>Material</i>	<i>Factor of Safety</i>
For concrete 3.0	For Steel 1.78

### Assumptions of WSM

The analysis and design of a RCC member are based on the following assumptions.

- (i) Concrete is assumed to be homogeneous.
- (ii) At any cross section, plane sections before bending remain plane after bending.
- (iii) The stress-strain relationship for concrete is a straight line, under working loads.
- (iv) The stress-strain relationship for steel is a straight line, under working loads.
- (v) Concrete area on tension side is assumed to be ineffective.
- (vi) All tensile stresses are taken up by reinforcements and none by concrete except when specially permitted.
- (vii) The steel area is assumed to be concentrated at the centroid of the steel.
- (viii) The modular ratio has the value  $280/3\sigma_{cbc}$  where  $\sigma_{cbc}$  is permissible stress in compression due to bending in concrete in  $N/mm^2$  as specified in code (IS:456-2000)

### Moment of Resistance

- (a) *For Balanced section:* When the maximum stresses in steel and concrete simultaneously reach their allowable values, the section is said to be a 'Balanced Section'. The moment of resistance shall be provided by the couple developed by compressive force acting at the centroid of stress diagram on the area of concrete in compression and tensile force acting at the centroid of reinforcement multiplied by the distance between these forces. This distance is known as 'lever arm'.

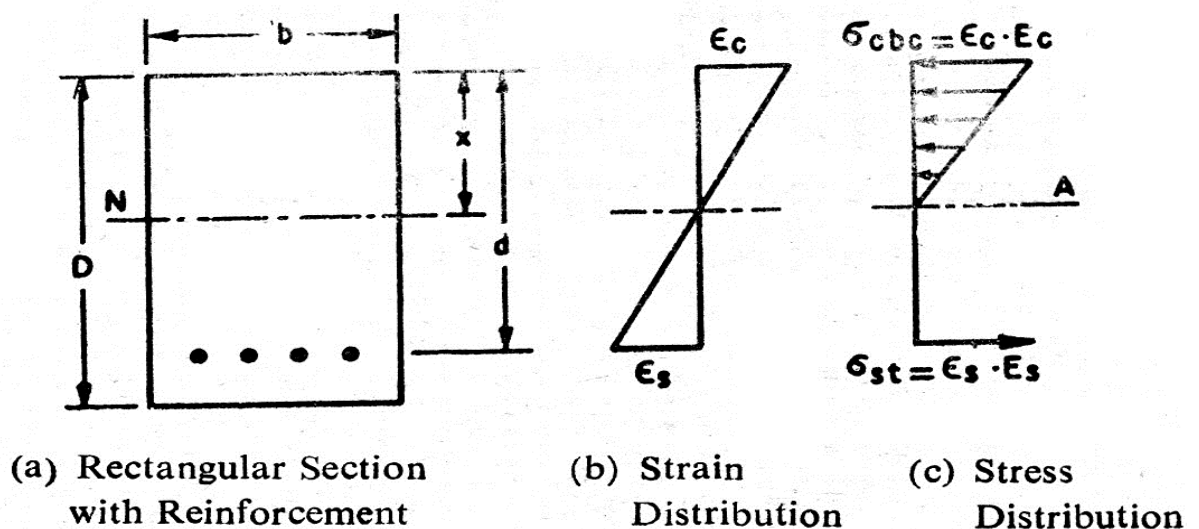

Fig.2.1 (a-c)

Let in Fig.2.1(a-c):  $b$  = width of section

$D$  = overall depth of section

$d$  = effective depth of section (distance from extreme compression fiber to the centroid of steel area,

$A_s$  = area of tensile steel

$\epsilon_c$  = Maximum strain in concrete,

$\epsilon_s$  = maximum strain at the centroid of the steel,

$\sigma_{cbc}$  = maximum compressive stress in concrete in bending

$\sigma_{st}$  = Stress in steel

$E_s/E_c$  = ratio of Young's modulus of elasticity of steel to concrete  
= modular ratio ' $m$ '

Since the strains in concrete and steel are proportional to their distances from the neutral axis,

$$\frac{\epsilon_c}{\epsilon_s} = \frac{x}{d-x} \quad \text{or} \quad \frac{d-x}{x} = \frac{\epsilon_s}{\epsilon_c}$$

$$\frac{d}{x} - 1 = \frac{\sigma_{st} E_c}{E_s \sigma_{cbc}} = \frac{\sigma_{st}}{\sigma_{cbc}} m$$

Or 
$$\frac{d}{x} = 1 + \frac{\sigma_{st}}{m \cdot \sigma_{cbc}} \quad \text{or} \quad x = \frac{1}{1 + \frac{\sigma_{st}}{m \cdot \sigma_{cbc}}} \cdot d = k \cdot d$$

Where  $k$  = neutral axis constant = 
$$\frac{1}{1 + \frac{\sigma_{st}}{m \cdot \sigma_{cbc}}}$$

Total compressive force = 
$$\frac{b \cdot s \cdot a_{cbc}}{2}$$

Total tensile forces =  $a_{ct} \cdot A_c$   
 $Z$  = Lever arm = 
$$d - \frac{x}{3} = d - \frac{k \cdot d}{3} = d \left( 1 - \frac{k}{3} \right) = j \cdot d$$

Where  $j$  is called the lever arm constant.

Moment of resistance = 
$$MR = \frac{b \cdot x}{2} \cdot \sigma_{cbc} \cdot j \cdot d = \frac{k \cdot d \cdot j}{2} \cdot \sigma_{cbc} \cdot b \cdot d = \frac{1}{2} \cdot k \cdot j \cdot \sigma_{cbc} \cdot b \cdot d^2 = Q \cdot b \cdot d^2$$

Where  $Q$  is called moment of resistance constant and is equal to 
$$\frac{1}{2} \cdot k \cdot j \cdot a_{cbc}$$

**(b) Under reinforced section**

When the percentage of steel in a section is less than that required for a balanced section, the section is called 'Under-reinforced section.' In this case (Fig.2.2) concrete stress does not reach its maximum allowable value while the stress in steel reaches its maximum permissible value. The position of the neutral axis will shift upwards, i.e., the neutral axis depth will be smaller than that in the balanced section as shown in Figure2.2. The moment of resistance of such a section will be governed by allowable tensile stress in steel.

$$\text{Moment of resistance} = \sigma_{st} \cdot A_s \left( d - \frac{x}{3} \right) = \sigma_{st} A_s \cdot j \cdot d \quad \text{where } j' = 1 - \frac{k'}{3}$$

$$\text{Since } p = \frac{A_s \times 100}{b \cdot d}$$

$$\text{Moment of resistance} = \sigma_{st} \cdot p \cdot \frac{b \cdot d}{100} \cdot j' \times d = \frac{\sigma_{st} \cdot p \cdot j'}{100} \cdot b \cdot d^2 = Q' \cdot Bb \cdot d^2 \quad \text{where } Q' = \frac{\sigma_{st} \cdot p \cdot j'}{100}$$

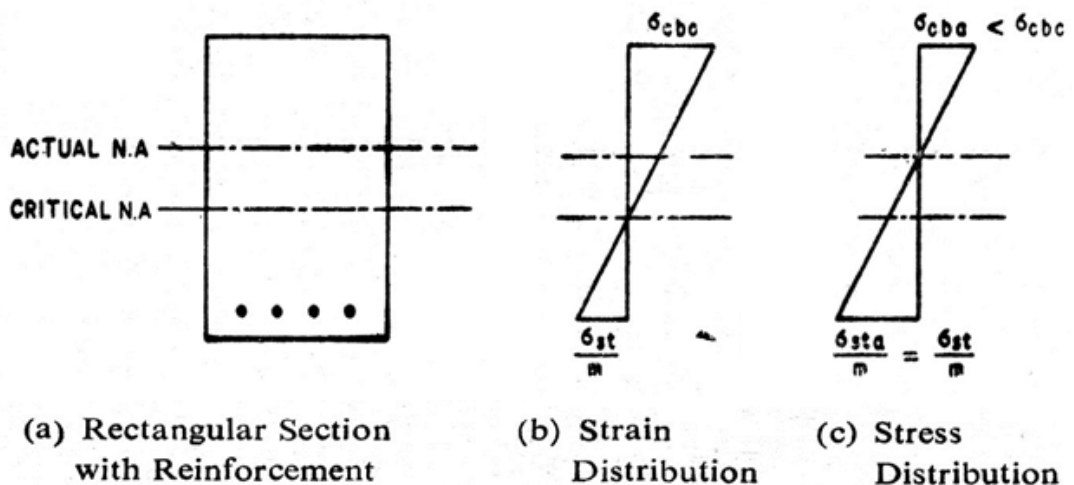

Fig.2.2 (a-c)

**(c) Over reinforced section:**

When the percentage of steel in a section is more than that required for a balanced section, the section is called 'Over-reinforced section'. In this case (Fig.2.3) the stress in concrete reaches its maximum allowable value earlier than that in steel. As the percentage steel is more, the position of the neutral axis will shift towards steel from the critical or balanced neutral axis position. Thus the neutral axis depth will be greater than that in case of balanced section.

Moment of resistance of such a section will be governed by compressive stress in concrete,

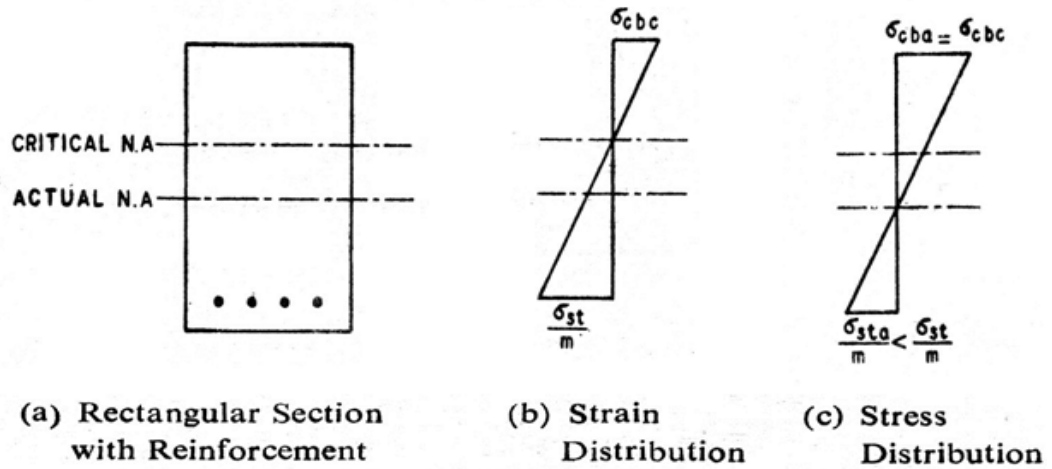

Fig.2.3 (a-c)

$$\begin{aligned} \text{Moment of resistance} &= b.x.\sigma_{cbc} \cdot \frac{1}{2} \left( d - \frac{x}{3} \right) = \frac{\sigma_{cbc}}{2} \cdot b.x.d \left( 1 - \frac{k'}{3} \right) \\ &= \frac{\sigma_{cbc}}{2} \cdot b.x.d.j' = \frac{1}{2} \cdot \sigma_{cbc} \cdot k'.j'.b.d^2 = Q'.b.d^2 \quad \text{where } Q' = \frac{\sigma_{cbc}}{2} \cdot k'.j' = \text{Constant} \end{aligned}$$

## 2.2 Basic concept of design of single reinforced members

The following types of problems can be encountered in the design of reinforced concrete members.

### (A) Determination of Area of Tensile Reinforcement

The section, bending moment to be resisted and the maximum stresses in steel and concrete are given.

*Steps to be followed:*

- (i) Determine  $k, j, Q'$  (or  $Q'$ ) for the given stress.
- (ii) Find the critical moment of resistance,  $M = Q'.b.d^2$  from the dimensions of the beam.
- (iii) Compare the bending moment to be resisted with  $M$ , the critical moment of resistance.
- (a) If B.M. is less than  $M$ , design the section as under reinforced.

$$M = \sigma_{st} \cdot A_s \left( d - \frac{x}{3} \right)$$

To find  $A_s$  in terms of  $x$ , take moments of areas about  $N.A.$

$$b.x \cdot \frac{x}{2} = m.A_s \cdot (d - x)$$

$$A_s = \frac{b.x^2}{2(m)(d-x)} \therefore M = \frac{\sigma_{st}}{2.m} \cdot \frac{b.x^2}{(d-x)} \left( d - \frac{x}{3} \right) = B.M. \text{ to be resisted}$$

Solve for 'x', and then  $A_s$  can be calculated.

- (b) If  $B.M.$  is more than  $M$ , design the section as over-reinforced.

$$M = \frac{\sigma_{cbc}}{2} \cdot b \cdot x \cdot \left( d - \frac{x}{3} \right) = B.M. \text{ to be resisted. Determine 'x'. Then } A_s \text{ can be obtained by taking}$$

moments of areas (compressive and tensile) about using the following expression.

$$A_s = \frac{b \cdot x^2}{2 \cdot m \cdot (d - x)}$$

### (B) Design of Section for a Given loading

Design the section as balanced section for the given loading.

*Steps to be followed:*

- (i) Find the maximum bending moment ( $B.M.$ ) due to given loading.
- (ii) Compute the constants  $k, j, Q$  for the balanced section for known stresses.
- (iii) Fix the depth to breadth ratio of the beam section as 2 to 4.
- (iv) From  $M = Q \cdot b \cdot d^2$ , find 'd' and then 'b' from depth to breadth ratio.
- (v) Obtain overall depth 'D' by adding concrete cover to 'd' the effective depth.
- (vi) Calculate  $A_s$  from the relation

$$A_s = \frac{B.M.}{\sigma_{st} \cdot j \cdot d}$$

### (C) To Determine the Load carrying Capacity of a given Beam

The dimensions of the beam section, the material stresses and area of reinforcing steel are given.

*Steps to be followed:*

- (i) Find the position of the neutral axis from section and reinforcement given.
- (ii) Find the position of the critical  $N.A.$  from known permissible stresses of concrete and steel.

$$x = \frac{1}{1 + \frac{\sigma_{st}}{m \cdot \sigma_{cbc}}} \cdot d$$

- (iii) Check if (i) > (ii)- the section is over-reinforced

(i) < (ii)- the section is under-reinforced

- (iv) Calculate  $M$  from relation

$$M = b \cdot x \cdot \frac{1}{2} \cdot \sigma_{cbc} \cdot \left( d - \frac{x}{3} \right) \text{ for over-reinforced section}$$



and  $M = \sigma_{st} \cdot A_s \cdot \left( d - \frac{x}{3} \right)$  for under-reinforced section.

- (v) If the effective span and the support conditions of the beam are known, the load carrying capacity can be computed.

#### (D) To Check The Stresses Developed In Concrete And Steel

The section, reinforcement and bending moment are given.

*Steps to be followed:*

- (i) Find the position of N.A. using the following relation.

$$b \cdot \frac{x^2}{2} = m \cdot A_s \cdot (d - x)$$

- (ii) Determine lever arm,  $z = d - \frac{x}{3}$

- (iii)  $B.M. = \sigma_{st} \cdot A_s \cdot z$  is used to find out the actual stress in steel  $\sigma_{sa}$ .

- (iv) To compute the actual stress in concrete  $\sigma_{cba}$ , use the following relation.

$$BM = \frac{\sigma_{cba}}{2} \cdot b \cdot x \cdot z$$

#### Doubly Reinforced Beam Sections by Working Stress Method

Very frequently it becomes essential for a section to carry bending moment more than it can resist as a balanced section. Such a situation is encountered when the dimensions of the cross section are limited because of structural, head room or architectural reasons. Although a balanced section is the most economical section but because of limitations of size, section has to be sometimes over-reinforced by providing extra reinforcement on tension face than that required for a balanced section and also some reinforcement on compression face. Such sections reinforced both in tension and compression are also known as “Doubly Reinforced Sections”. In some loading cases reversal of stresses in the section take place (this happens when wind blows in opposite directions at different timings), the reinforcement is required on both faces.

## MOMENT OF RESISTANCE OF DOUBLY REINFORCED SECTIONS

Consider a rectangular section reinforced on tension as well as compression faces as shown in Fig.2.4 (a-c)

Let  $b$  = width of section,

$d$  = effective depth of section,

$D$  = overall depth of section,

$d'$  = cover to centre of compressive steel,

$M$  = Bending moment or total moment of resistance,

$M_{bal}$  = Moment of resistance of a balanced section with tension reinforcement,

$A_{st}$  = Total area of tensile steel,

$A_{st1}$  = Area of tensile steel required to develop  $M_{bal}$

$A_{st2}$  = Area of tensile steel required to develop  $M_2$

$A_{sc}$  = Area of compression steel,

$\sigma_{st}$  = Stress in steel, and

$\sigma_{sc}$  = Stress in compressive steel

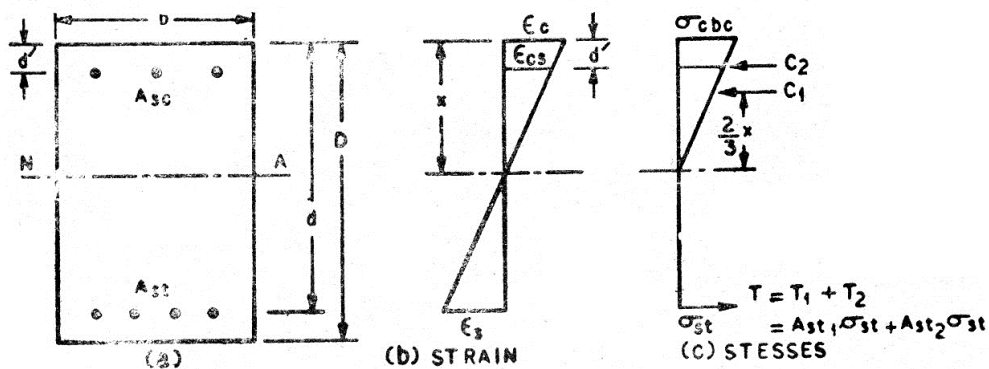

Fig.2.4 (a-c)

Since strains are proportional to the distance from  $N.A.$ ,

$$\frac{\text{Strain in top fibre of concrete}}{\text{Strain in Compression Steel}} = \frac{x}{x - d'}$$

$$\frac{\sigma_{cbc}/E_c}{\sigma_{sc}/E_s} = \frac{x}{x - d'}$$

$$\frac{\sigma_{cbc}}{\sigma_{sc}} \cdot \frac{E_s}{E_c} = \frac{x}{x - d'}$$

$$\sigma_{sc} = \sigma_{cbc} \cdot \frac{x}{x - d'}$$

Since  $\sigma_{cbc} \cdot \frac{x-d'}{x}$  is the stress in concrete at the level of compression steel, it can be denoted as

$$\sigma'_{cbc}$$

$$\therefore \sigma_{sc} = m \cdot \sigma'_{cbc}$$

As per the provisions of IS:456-2000 Code, the permissible compressive stress in bars, in a beam or slab when compressive resistance of the concrete is taken into account, can be taken as 1.5m times the compressive stress in surrounding concrete ( $1.5m \sigma'_{cbc}$ ) or permissible stress in steel in compression ( $\sigma_{sc}$ ) whichever is less.

$$\sigma_{sc} = 1.5m \sigma'_{cbc}$$

Total equivalent concrete area resisting compression

$$(x \cdot b - A_{sc}) + 1.5mA_{sc} = x \cdot b + (1.5m-1)A_{sc}$$

Taking moment about centre of tensile steel

$$\text{Moment of resistance } M = C_1 \cdot (d-x/3) + C_2(d-d')$$

Where  $C_1$  = total compressive force in concrete,

$C_2$  = total compressive force in compression steel,

$$\begin{aligned} M &= b \cdot x \cdot \frac{\sigma_{cbc}}{2} \cdot \left(d - \frac{x}{3}\right) + (1.5m-1) A_{sc} \cdot \sigma_{sc} \cdot \frac{x-d'}{x} \cdot (d-d') = Q \cdot b \cdot d^2 + (1.5m-1) A_{sc} \cdot \sigma_{sc} \cdot \frac{x-d'}{x} (d-d') \\ &= M_1 + M_2 \end{aligned}$$

Where  $M_1$  = Moment of resistance of the balanced section =  $M_{bal}$

$M_2$  = Moment of resistance of the compression steel

$$\text{Area of tension steel} = A_{st1} = \frac{M_1}{\sigma_{st} \cdot j \cdot d}$$

$$\text{Area of tension steel equivalent to compression steel} = A_{st2} = \frac{M_2}{\sigma_{st} (d-d')}$$

Thus the total tensile steel  $A_{st}$  shall be:

$$\therefore A_{st} = A_{st1} + A_{st2}$$

The area of compression steel can be obtained as

$$(1.5m-1) A_{sc} (x-d') = mA_{st2} \cdot (d-x)$$

### Design Concept of T-Beam

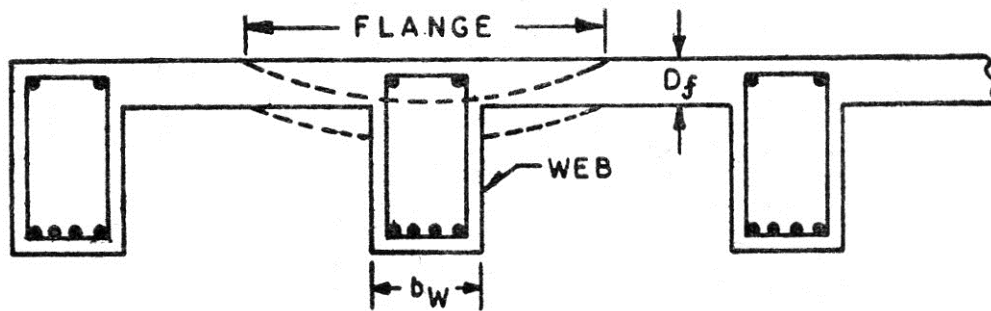

Fig.2.5

Flanged beam sections comprise T-beams and L-beams where the slabs and beams are cast monolithically having no distinction between beams and slabs. Consequently the beams and slabs are so closely tied that when the beam deflects under applied loads it drags along with it a portion of the slab also as shown in Fig.2.5. This portion of the slab assists in resisting the effects of the loads and is called the 'flange' of the T-beams. For design of such beams, the profile is similar to a T-section for intermediate beams. The portion of the beam below the slab is called 'web' or 'Rib'. A slab which is assumed to act as flange of a T-beam shall satisfy the following conditions:

- (a) The slab shall be cast integrally with the web or the web and the slab shall be effectively bonded together in any other manner; and
- (b) If the main reinforcement of the slab is parallel to the beam, transverse reinforcement shall be provided as shown in Fig.2.6, such reinforcement shall not be less than 60% of the main reinforcement at mid-span of the slab.

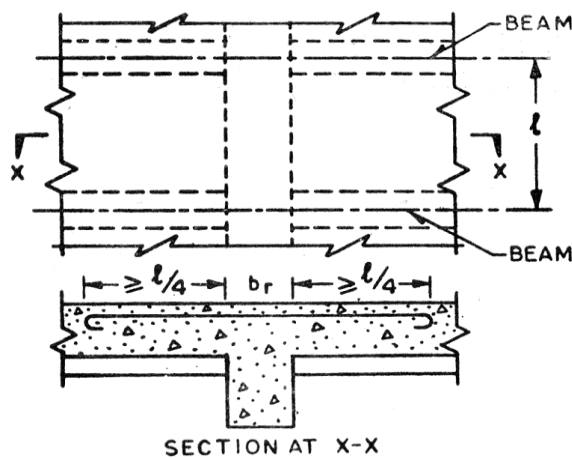

Fig.2.6

## **CHAPTER- 2**

### **PHILOSOPHY OF**

### **LIMIT STATE METHOD**

#### **SAFETY AND SERVICEABILITY REQUIREMENTS**

In the method of design based on limit state concept, the structure shall be designed to withstand safely all loads liable to act on it throughout its life; it shall also satisfy the serviceability requirements, such as limitations on deflection and cracking. The acceptable limit for the safety and serviceability requirements before failure occurs is called a 'limit state'. The aim of design is to achieve acceptable probabilities that the structure will not become unfit for the use for which it is intended that it will not reach a limit state.

All relevant limit states shall be considered in design to ensure an adequate degree of safety and serviceability. In general, the structure shall be designed on the basis of the most critical limit state and shall be checked for other limit states.

For ensuring the above objective, the design should be based on characteristic values for material strengths and applied loads, which take into account the variations in the material strengths and in the loads to be supported. The characteristic values should be based on statistical data if available; where such data are not available they should be based on experience. The 'design values' are derived from the characteristic values through the use of partial safety factors, one for material strengths and the other for loads. In the absence of special considerations these factors should have the values given in 36 according to the material, the type of loading and the limit state being considered.

#### **Limit State of Collapse**

The limit state of collapse of the structure or part of the structure could be assessed from rupture of one or more critical sections and from buckling due to elastic or plastic instability (including the effects of sway where appropriate) or overturning. The resistance to bending, shear, torsion and axial loads at every section shall not be less than the appropriate value at that section produced by the probable most unfavourable combination of loads on the structure using the appropriate partial safety factors.

#### **Limit State Design**

For ensuring the design objectives, the design should be based on characteristic values for material strengths and applied loads (actions), which take into account the probability of variations in the material strengths and in the loads to be supported. The characteristic values should be based on statistical data, if available. Where such data is not available, they should be based on experience. The design values are derived from the characteristic values through the use of partial safety factors, both for material strengths and for loads. In the absence of special considerations, these factors should have the values given in this section according to the material, the type of load and the limit state being considered. The reliability of design is ensured by requiring that

$$\text{Design Action} \leq \text{Design Strength.}$$

Limit states are the states beyond which the structure no longer satisfies the performance requirements specified. The limit states are classified as

- a) Limit state of strength
- b) Limit state of serviceability

**a)** The limit state of strength are those associated with failures (or imminent failure), under the action of probable and most unfavorable combination of loads on the structure using the appropriate partial safety factors, which may endanger the safety of life and property. The limit state of strength includes:

- a) Loss of equilibrium of the structure as a whole or any of its parts or components.
- b) Loss of stability of the structure (including the effect of sway where appropriate and overturning) or any of its parts including supports and foundations.
- c) Failure by excessive deformation, rupture of the structure or any of its parts or components.
- d) Fracture due to fatigue.
- e) Brittle fracture.

**b)** The limit state of serviceability include

- a) Deformation and deflections, which may adversely affect the appearance or, effective, use of the structure or may cause improper functioning of equipment or services or may cause damages to finishes and non-structural members.
- b) Vibrations in the structure or any of its components causing discomfort to people, damages to the structure, its contents or which may limit its functional effectiveness. Special consideration shall be given to floor vibration systems susceptible to vibration, such as large open floor areas free of partitions to ensure that such vibrations is acceptable for the intended use and occupancy.
- c) Repairable damage due to fatigue.
- d) Corrosion and durability.

### **Limit States of Serviceability**

To satisfy the limit state of serviceability the deflection and cracking in the structure shall not be excessive. This limit state corresponds to deflection and cracking.

#### **Deflection**

The deflection of a structure or part shall not adversely affect the appearance or efficiency of the structure or finishes or partitions.

#### **Cracking**

Cracking of concrete should not adversely affect the appearance or durability of the structure; the acceptable limits of cracking would vary with the type of structure and environment. The actual width of cracks will vary between the wide limits and predictions of absolute maximum width are not possible. The surface width of cracks should not exceed 0.3mm.

In members where cracking in the tensile zone is harmful either because they are exposed to the effects of the weather or continuously exposed to moisture or in contact soil or ground water, an upper limit of 0.2 mm is suggested for the maximum width of cracks. For particularly aggressive environment, such as the 'severe' category, the assessed surface width of cracks should not in general, exceed 0.1 mm.

## **CHARACTERISTIC AND DESIGN VALUES AND PARTIAL SAFETY FACTORS**

### **1. Characteristic Strength of Materials**

Characteristic strength means that value of the strength of the material below which not more than 5 percent of the test results are expected to fall and is denoted by  $f$ . The characteristic strength of concrete ( $f_{ck}$ ) is as per the mix of concrete. The characteristic strength of steel ( $f_y$ ) is the minimum stress or 0.2 percent of proof stress.

### **2. Characteristic Loads**

Characteristic load means that value of load which has a 95 percent probability of not being exceeded during the life of the structure. Since data are not available to express loads in statistical terms, for the purpose of this standard, dead loads given in IS 875 (Part 1), imposed loads given in IS 875 (Part 2), wind loads given in IS 875 (Part 3), snow load as given in IS 875 (Part 4) and seismic forces given in IS 1893-2002(part-I) shall be assumed as the characteristic loads.

### **Design Values**

#### **Materials**

The design strength of the materials  $f_d$  is given by

$$f_d = \frac{f}{\gamma_m}$$

where

$f$  = characteristic strength of the material

$\gamma_m$  = partial safety factor appropriate to the material and the limit state being considered.

#### **Load**

The design load,  $F$ , is given by

$$f_d = \frac{F}{\gamma_f}$$

Where,  $F$  = characteristic load

and  $\gamma_f$  = partial safety factor appropriate to the nature of loading and the limit state being considered.

### **Consequences of Attaining Limit State**

Where the consequences of a structure attaining a limit state are of a serious nature such as huge loss of life and disruption of the economy, higher values for  $\gamma_f$  and  $\gamma_m$  than those given under 36.4.1 and 36.4.2 may be applied.

## Partial Safety Factors:

### 1. Partial Safety Factor $\gamma_f$ for Loads

Sr. No.	Load Combination	Ultimate Limit State	Serviceability Limit State
1	DL + LL	1.5 (DL + LL)	DL + LL
2	DL + WL i) DL contribute to stability ii) DL assists overturning	0.9 DL + 1.5 WL 1.5 (DL + WL)	DL + WL DL + WL
3	DL + LL + WL	1.2 (DL + LL + WL)	DL + 0.8 LL + 0.8 WL

### 2. Partial Safety Factor $\gamma_m$ for Material Strength

Sr. No.	Material	Ultimate Limit State	Serviceability Limit State
1	Concrete	1.50	$E_c = 5000\sqrt{f_{ck}}$ MPa
2	Steel	1.15	$E_s = 2 \times 10^5$ MPa

When assessing the strength of a structure or structural member for the limit state of collapse, the values of partial safety factor, should be taken as 1.5 for concrete and 1.15 for steel.

## LIMIT STATE OF COLLAPSE: FLEXURE

### Assumptions for Limit State of Collapse (Flexure):

- 1) Plane section normal to the axis remains plane even after bending. i.e. strain at any point on the cross section is directly proportional to the distance from the N.A.
- 2) Maximum strain in concrete at the outer most compression fibre is taken as 0.0035 in bending.
- 3) The relationship between the compressive stress distribution in concrete and the strain in concrete may be assumed to be rectangle, trapezoid, parabola or any other shape which results in prediction of strength in substantial agreement with the results of test. An acceptable stress strain curve is as shown below.

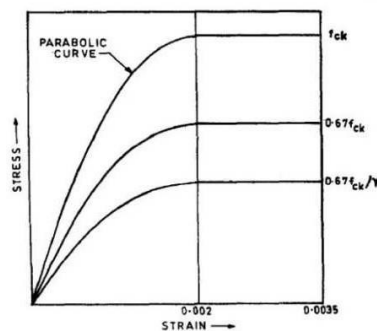

STRESS-STRAIN CURVE FOR CONCRETE

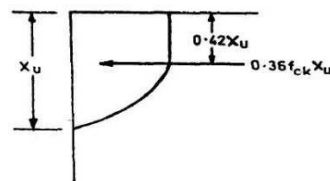

STRESS BLOCK PARAMETERS



For design purposes, the compressive strength of concrete in the structure shall be assumed to be 0.67 times the characteristic strength. The partial safety factor  $\gamma_m = 1.5$  shall be applied in addition to this.

**NOTE** - For the above stress-strain curve the design stress block parameters are as follows:

Area of stress block =  $0.36 \cdot f_{ck} \cdot x_u$

Depth of centre of compressive force =  $0.42 x_u$  from the extreme fibre in compression

Where

$f_{ck}$  = characteristic compressive strength of concrete, and

$x_u$  = depth of neutral axis.

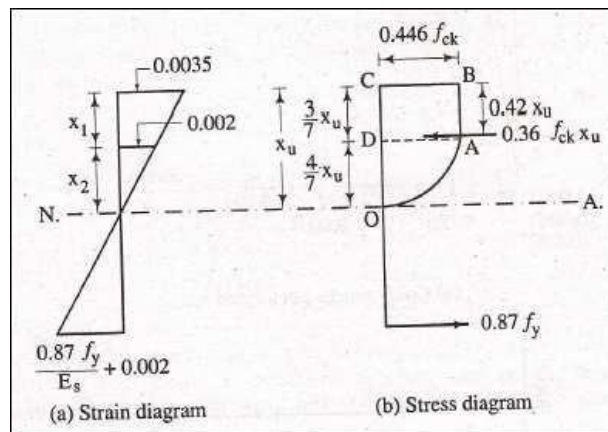

- 4) the tensile strength of the concrete is ignored.
- 5) the stresses in the reinforcement are derived from representative stress – strain curve for the type of steel used.

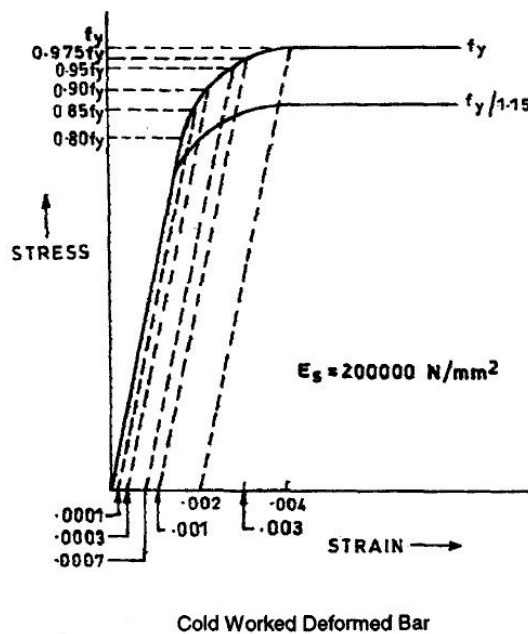

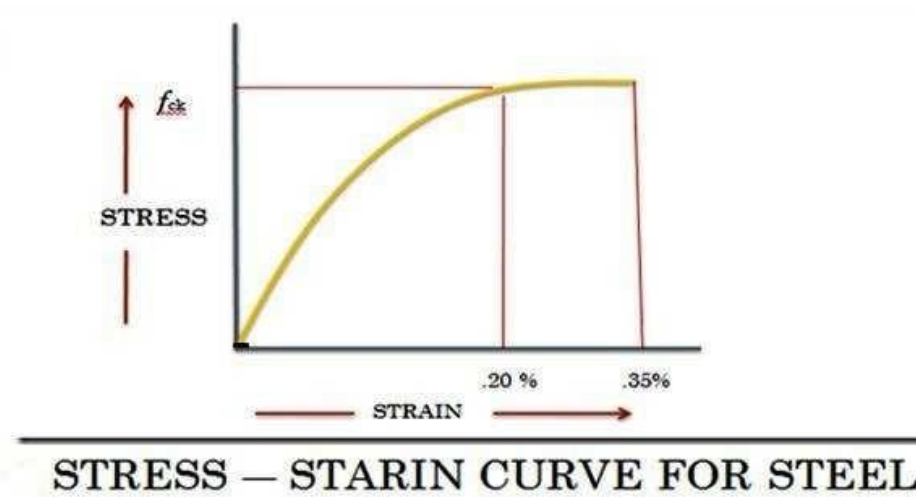

- 6) the maximum strain in tension reinforcement in the section at failure shall not be less than

$$\frac{f_y}{1.15E_s} + 0.002 = \frac{0.87f_y}{E_s} + 0.002$$

## CHAPTER -3

### ANALYSIS AND DESIGN OF SINGLY AND DOUBLY REINFORCED MEMBERS

#### Limit state method of design

- The object of the design based on the limit state concept is to achieve an acceptable probability, that a structure will not become unsuitable in its lifetime for the use for which it is intended, i.e. It will not reach a limit state
- A structure with appropriate degree of reliability should be able to withstand safely.
- All loads, that are reliable to act on it throughout its life and it should also satisfy the serviceability requirements, such as limitation on deflection and cracking.
- It should also be able to maintain the required structural integrity, during and after accident, such as fires, explosion & local failure. i.e. limit state must be considered in design to ensure an adequate degree of safety and serviceability
- The most important of these limit states, which must be examined in design are as follows      Limit state of collapse

- Flexure
- Compression
- Shear
- Torsion

This state corresponds to the maximum load carrying capacity.

#### Types of reinforced concrete beams

- Singly reinforced beam
- Doubly reinforced beam
- Singly or Doubly reinforced flanged beams

#### Singly reinforced beam

In singly reinforced simply supported beams or slabs reinforcing steel bars are placed near the bottom of the beam or slabs where they are most effective in resisting the tensile stresses.

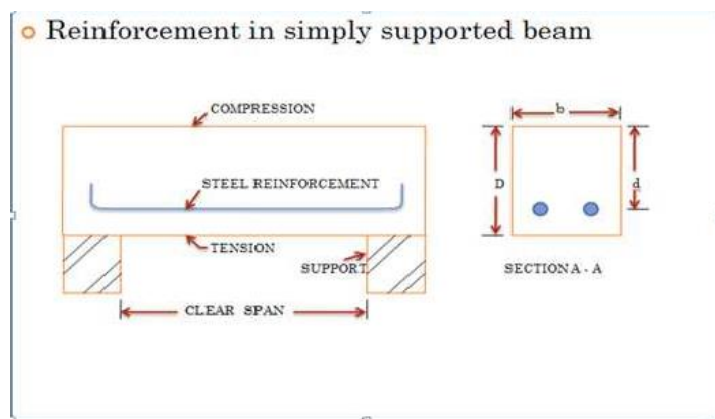

○ Reinforcement in a cantilever beam

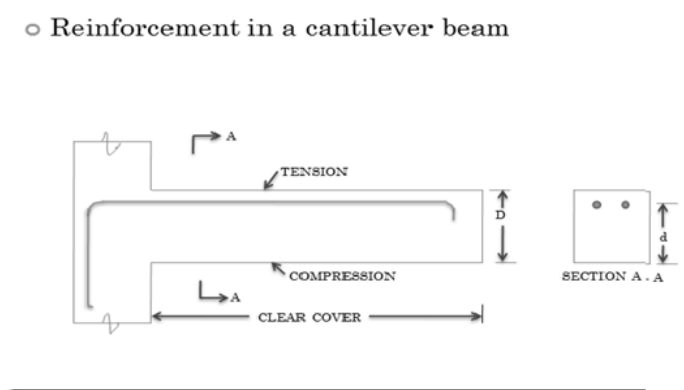

### TYPES OF BEAM SECTIONS

Section in which, tension steel also reaches yield strain simultaneously as the concrete reaches the failure strain in bending are called, **'Balanced Section'**.

Section in which, tension steel also reaches yield strain at loads lower than the load at which concrete reaches the failure strain in bending are called, **'Under Reinforced Section'**.

Section in which, tension steel also reaches yield strain at loads higher than the load at which concrete reaches the failure strain in bending are called, **'Over Reinforced Section'**.

Sr. No.	Types of Problems	Data Given	Data Determine								
1.	Identify the type of section, balance, under reinforced or over reinforced	Grade of Concrete & Steel, Size of beam & Reinforcement provided	<p>If <math>\frac{X_u}{d} = \frac{X_{u \max}}{d} \Rightarrow</math> Balanced</p> <p>If <math>\frac{X_u}{d} &lt; \frac{X_{u \max}}{d} \Rightarrow</math> Under Reinforced</p> <p>If <math>\frac{X_u}{d} &gt; \frac{X_{u \max}}{d} \Rightarrow</math> Over Reinforced</p> $\frac{X_u}{d} = \frac{0.87 f_y A_{st}}{0.36 b d f_{ck}}$ <table style="margin-left: auto; margin-right: auto;"> <tr> <td><math>f_y</math></td> <td><math>\frac{X_{u \max}}{d}</math></td> </tr> <tr> <td>250</td> <td>0.53</td> </tr> <tr> <td>415</td> <td>0.48</td> </tr> <tr> <td>500</td> <td>0.46</td> </tr> </table>	$f_y$	$\frac{X_{u \max}}{d}$	250	0.53	415	0.48	500	0.46
$f_y$	$\frac{X_{u \max}}{d}$										
250	0.53										
415	0.48										
500	0.46										

2	Calculate Moment of Resistance	Grade of Concrete & Steel, Size of beam & Reinforcement Provided	1) If $\frac{x_u}{d} = \frac{x_{u,max}}{d}$ , <i>balanced</i> $M .R = M_u = 0.36 \cdot \frac{x_{u,max}}{d} (1 - 0.42 \frac{x_{u,max}}{d}) b \cdot d^2 \cdot f_{ck}$
			2) If $\frac{x_u}{d} < \frac{x_{u,max}}{d}$ Under Reinforced $M.R = M_u = 0.87 f_y A_{st} d (1 - \frac{A_{st} f_y}{b \cdot d \cdot f_{ck}})$ or $M .R = 0.87 f_y A_{st} d (1 - 0.42 \frac{x_u}{d})$
			3) If $\frac{x_u}{d} > \frac{x_{u,max}}{d} \Rightarrow$ over reinforced, Revise the depth
3	Design the beam. Find out the depth of Beam D & Reinforcement required $A_{st}$ .	Grade of Concrete & Steel, width of beam & Bending Moment or loading on the beam with the span of the beam Reinforcement Provided	We have to design the beam as a 'Balanced Design'. For finding 'd' effective depth use the equation; $M .R = M_u = 0.36 \cdot \frac{x_{u,max}}{d} (1 - 0.42 \frac{x_{u,max}}{d}) b \cdot d^2 \cdot f_{ck}$ For finding $A_{st}$ use the equation $0.87 f_y A_{st} d (1 - \frac{A_{st} f_y}{b \cdot d \cdot f_{ck}})$ or $M .R = 0.87 f_y A_{st} d (1 - 0.42 \frac{x_u}{d})$

Where

d = effective depth of beam in mm.

b = width of beam in mm

$x_u$  = depth of actual neutral axis in mm from extreme compression fibre.

$x_{u,max}$  = depth of critical neutral axis in mm from extreme compression fibre.

$A_{st}$  = area of tensile reinforcement

$f_{ck}$  = characteristic strength of concrete in MPa.

$f_y$  = characteristic strength of steel in MPa.

$M_{u,lim}$  = Limiting Moment of Resistance of a section without compression reinforcement

### Doubly Reinforced Section or sections with Compression Reinforcement

Doubly Reinforced Section sections are adopted when the dimensions of the beam have been predetermined from other considerations and the design moment exceeds the moment of resistance of a singly reinforced section. The additional moment of resistance is carried by providing compression reinforcement and additional reinforcement in tension zone. The moment of resistance of a doubly reinforced section is the sum of the limiting moment of resistance  $M_{u,lim}$  of a single reinforced section and the additional moment of resistance  $M_{u2}$ .

$$M_{u2} = M_u - M_{u,lim}$$

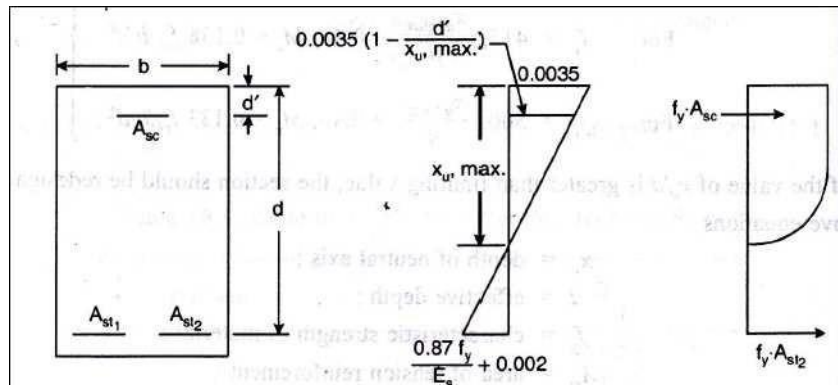

The lever arm for the additional moment of resistance is equal to the distance between the centroids of tension and compression reinforcement,  $(d - d')$ .

$$M_{u2} = 0.87 f_y \cdot A_{st2} (d - d') = A_{sc} \cdot (f_{sc} - f_{cc}) (d - d')$$

Where :  $A_{st2}$  = Area of additional tensile reinforcement

$A_{sc}$  = Area of compression reinforcement

$f_{sc}$  = Stress in compression reinforcement

$f_{cc}$  = Compressive stress in concrete at the level of compression reinforcement

Since the additional reinforcement is balanced by the additional compressive force.

$$A_{sc} \cdot (f_{sc} - f_{cc}) = 0.87 f_y \cdot A_{st2}$$

The strain at level of compression reinforcement is  $0.0035 \left(1 - \frac{d'}{x_{u,max.}}\right)$

Total area of reinforcement shall be obtained by

$$A_{st} = A_{st1} + A_{st2}$$

$A_{st1}$  = Area of reinforcement for a singly reinforced section for  $M_{u,lim}$

$$A_{st2} = \frac{A_{sc} (f_{sc} - f_{cc})}{0.87 f_y}$$

**EXAMPLE 4.1**

Calculate the area of steel of grade Fe 415 required for section of 250mm wide and overall depth 500mm with effective cover 40mm in M20, if the limit state of moment be carried by the section is

- a) 100 KN      b) 146 KN      c) 200KN

**SOLUTION:**

For  $f_y = 415 \text{ N/mm}^2$ ,  $\frac{x_{u,\max}}{d} = 0.48$

$$\begin{aligned} M_{u,\lim} &= 0.36 \cdot \frac{x_{u,\max}}{d} (1 - 0.42 \frac{x_{u,\max}}{d}) b \cdot d^2 \cdot f_{ck} \\ &= 0.36 \times 0.48 (1 - 0.42 \times 0.48) \times 250 \times 460^2 \times 20 \\ &= 146 \times 10^6 \text{ N.m} \end{aligned}$$

- a) For  $M_u = 100 \text{ KN.m} < 146 \text{ KN.m}$

Area of steel required is obtained from,  $M_u = 0.87 f_y A_{st} d (1 - \frac{A_{st} f_y}{b \cdot d \cdot f_{ck}})$

$$100 \times 10^6 = 0.87 \times 415 \times A_{st} \times 460 (1 - \frac{A_{st} \times 415}{250 \times 460 \times 20})$$

$A_{st} = 686$  or  $4850 \text{ mm}^2$ , taking minimum steel  $686 \text{ mm}^2$

- b)  $M_u = 146 \text{ KN.m} = M_{u,\lim} = 146 \text{ KN.m}$

$$x_u = x_{u,\max}$$

Area of tension reinforcement required

$$\begin{aligned} \frac{x_{u,\max}}{d} &= \frac{0.87 f_y A_{st}}{0.36 b \cdot d \cdot f_{ck}} \\ A_{st} &= \frac{0.48 \times 0.36 \times 20 \times 250 \times 460}{0.87 \times 415} = 1100 \text{ mm}^2 \end{aligned}$$

- c)  $M_u = 200 \text{ KN.m} > M_{u,\lim} = 146 \text{ KN.m}$

Reinforcement is to be provided in the compression zone also along with the reinforcement in tension zone.

$$M_u = M_{u,\lim} = f_{sc} \cdot A_{sc} (d - d')$$

$$f_{sc} \text{ is stress corresponding to strain of } \frac{0.0035(x_{u,max} - d')}{x_{u,lim}} = \frac{0.0035(0.48 \times 460 - 40)}{0.48 \times 460} = 0.002866$$

$$f_{sc} = 360.8 \text{ N/mm}^2$$

$$(200 - 146) \times 10^6 = 360.8 \cdot A_{sc}(460 - 40)$$

$$A_{sc} = 356 \text{ mm}^2$$

$A_{st1}$  = Area of tension reinforcement corresponding to  $M_{u,lim}$

$$146 \times 10^6 = 0.87 \times 460 \times 415 A_{st1} \left(1 - \frac{A_{st1} \times 415}{250 \times 460 \times 20}\right)$$

$$A_{st1} = 1094 \text{ mm}^2$$

$$A_{st2} = A_{sc} \cdot f_{sc} / 0.87 \times 415 = 356 \text{ mm}^2$$

$$A_{st} = A_{st1} + A_{st2} = 1094 + 356 = 1450 \text{ mm}^2$$

#### EXAMPLE: 4.2

Design a rectangular beam which carries a maximum limiting bending moment of 65 KN.m. Use M20 and Fe 415 as reinforcement.

At balanced failure condition

$$M_u = M_{u,lim}$$

$$M_{u,lim} = 0.36 \cdot \frac{x_{u,max}}{d} \left(1 - 0.42 \frac{x_{u,max}}{d}\right) b \cdot d^2 \cdot f_{ck}$$

$$\begin{aligned} M_{u,lim} &= 0.36 \times 0.48 \times 20 (1 - 0.42 \times 0.48) b d^2 \\ &= 2.759 b d^2 \end{aligned}$$

Assuming width of beam as 250 mm

$$d = \sqrt{\frac{65 \times 10^6}{2.759 \times 250}} = 307 \text{ mm}$$

Area of reinforcement

$$\frac{x_{u,max}}{d} = \frac{0.87 f_y A_{st}}{0.36 b d f_{ck}}$$

$$0.48 = \frac{0.87 \times 415 \times A_{st}}{0.36 \times 20 \times 250 \times 307}$$

$$A_{st} = 734.66 \text{ mm}^2$$



**EXAMPLE: 4.3**

Find out the factored moment of resistance of a beam section 300mm wide X 450mm effective depth reinforced with 2 X 20mm diameter bars as compression reinforcement at an effective cover of 50mm and 4 X 25mm diameter bars as tension reinforcement. The materials are M20 grade concrete and Fe 415 HYSD bars.

**Solution:**

Given;

$$\text{Width} = b = 300\text{mm}$$

$$\text{Effective depth} = d = 450\text{mm}$$

$$\text{Cover to compression reinforcement} = d' = 50\text{mm}$$

$$\frac{d}{d'} = \frac{50}{450} = 0.11, \text{ next higher value } 0.15 \text{ may be adopted.}$$

$$A_{sc} = \text{area compression reinforcement} = 2 \pi 16^2 = 628\text{mm}^2$$

$$A_{st} = \text{area of reinforcement in tension} = 4 \times \pi 25^2 = 1964\text{mm}^2$$

$$f_{sc} = \text{stress in compression steel} = 342\text{N/mm}^2$$

Equating total force

$$0.36f_{ck} \cdot b \cdot x_u + f_{sc} \cdot A_{sc} = 0.87 f_y \cdot A_{st}$$

$$0.36 \times 20 \times 300 x_u + 628 \times 342 = 0.87 \times 415 \times 1964$$

$$x_u = 228.85\text{mm}$$

But  $x_{u,\max} = 0.48d$  for Fe415

$$x_{u,\max} = 0.48 \times 450 = 216\text{mm}$$

So  $x_u > x_{u,\max} \Rightarrow$  over reinforced

The moment of resistance can be found out by taking moments of compressive forces about centroid of tensile reinforcement.

$$M_u = 2160x_u(450 - 0.42x_u) + 214776 (450 - 50) \times 10^{-6}$$

$$\text{Putting } x_u = 216\text{mm}$$

$$M_u = 253.54 \text{ KN.m}$$

### BEHAVIORS OF 'T' AND 'L' BEAMS (FLANGED BEAM)

A 'T' beam or 'L' beam can be considered as a rectangular beam with dimensions  $b_w$ ,  $D$  plus a flange of size  $(b_f - b_w) \times D_f$ . It is shown in the figure beam (a) is equivalent to beam (b) + beam (c).

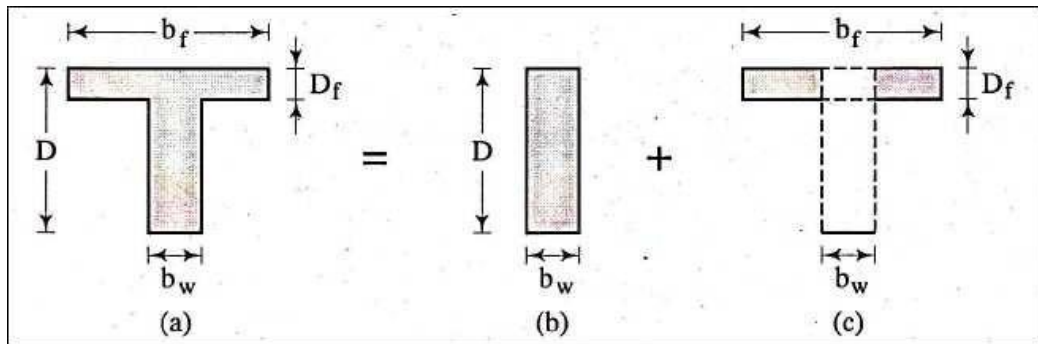

The flanged beam analysis and design are analogous to doubly reinforced rectangular beam. In doubly reinforced beams additional compressive is provided by adding reinforcement in compression zone, whereas in flanged beams, this is provided by the slab concrete, where the spanning of the slab is perpendicular to that of beam and slab is in compression zone.

If the spanning of the slab is parallel to that of the beam, some portion of slab can be made to span in the direction perpendicular to that of the beam by adding some reinforcement in the slab.

A flanged beam can be also doubly reinforced.

The moment of resistance of a T beam is sum of the moment of resistance of beam (a) is the sum moment of resistance of beam (b) and moment of resistance of beam (c)



## CHAPTER-4

### SHEAR, BOND, DEVELOPMENT LENGTHS

#### 5. BOND:

One of the most important assumption in the behavior of reinforced concrete structure is that there is proper 'bond' between concrete and reinforcing bars. The force which prevents the slippage between the two constituent materials is known as bond. In fact, bond is responsible for providing 'strain compatibility' and composite action of concrete and steel. It is through the action of bond resistance that the axial stress (tensile or compressive) in a reinforcing bar can undergo variation from point to point along its length. This is required to accommodate the variation in bending moment along the length of the flexural member.

When steel bars are embedded in concrete, the concrete, after setting, adheres to the surface of the bar and thus resists any force that tends to pull or push this rod. The intensity of this adhesive force bond stress. The bond stresses are the longitudinal shearing stress acting on the surface between the steel and concrete, along its length. Hence bond stress is also known as interfacial shear. Hence bond stress is the shear stress acting parallel to the reinforcing bar on the interface between the bar and the concrete.

#### 5.1 TYPES OF BOND:-

Bond stress along the length of a reinforcing bar may be induced under two loading situations, and accordingly bond stresses are two types :

1. Flexural bond or Local bond
2. Anchorage bond or development bond

**Flexural bond ( $\tau_{bf}$ )** is one which arises from the change in tensile force carried by the bar, along its length, due to change in bending moment along the length of the member. Evidently, flexural bond is critical at points where the shear ( $V=dM/dx$ ) is significant. Since this occurs at a particular section, flexural bond stress is known as local bond stress [Fig- 5.1(b)].

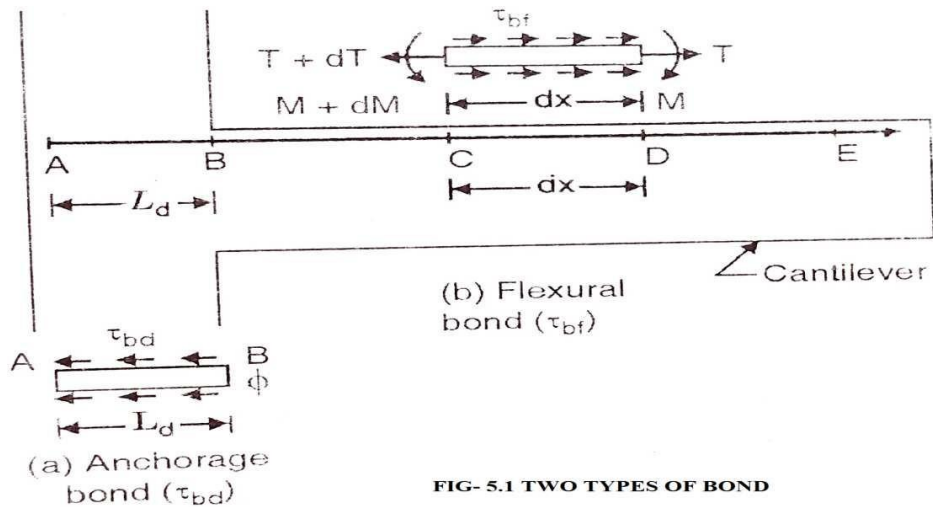

FIG- 5.1 TWO TYPES OF BOND

**Anchorage bond ( $\tau_{bd}$ )** is that which arises over the length of anchorage provided for a bar. It also arises near the end or cutoff point of reinforcing bar. The anchorage bond resists the ‘pulling out’ of the bar if it is in tension or ‘pushing in’ of the bar if it is in compression. Fig.[8.1 (a)] shows the situation of anchorage bond over a length AB(= $L_d$ ). Since bond stresses are developed over specified length  $L_d$ , anchorage bond stress is also known as developed over a specified length  $L_d$ , anchorage bond stress is also known as development bond stress.

Anchoring of reinforcing bars is necessary when the development length of the reinforcement is larger than the structure. Anchorage is used so that the steel's intended tension load can be reached and pop-outs will not occur. Anchorage shapes can take the form of 180 or 90 degree hooks.

**5.2. ANCHORAGE BOND STRESS:**

Fig- 5.2 shows a steel bar embedded in concrete And subjected to a tensile force  $T$ . Due to this force There will be a tendency of bar to slip out and this tendency is resisted by the bond stress developed over the perimeter of the bar, along its length of embedment .

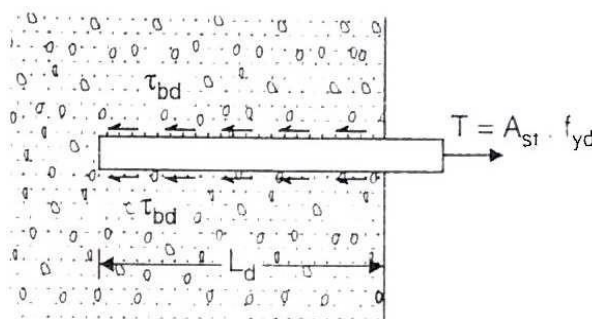

FIG- 5.2

Let us assume that average uniform bond stress is developed along the length. The required length necessary to develop full resisting force is called **Anchorage length** in case of axial tension or compression and **development length** in case of flexural tension and is denoted by  $L_d$ .

**5.3 DESIGN BOND STRESS:-**

The design bond stress in limit state method for plain bars in tension shall be as given below (Table 6.1)

Table- 6.1

Grade of concrete	M 20	M 25	M 30	M 35	M 40 and above
Design bond stress $\tau_{bd}$ (N/mm <sup>2</sup> )	1.2	1.4	1.5	1.7	1.9

**Design bond stresses for deformed bars in tension :** For deformed bars conforming to IS 1786. These values shall be increased by 60%.

**Design bond stress for bars in compression :** For bars in compression, the values of bond stress for in tension shall be increased by 25%.

**5.4 DEVELOPMENT LENGTH OF BARS (IS 456 : 2000)**

The development length is defined as the length of the bar required on either side of the section under consideration, to develop the required stress in steel at that section through bond. The development length  $L_d$  given by

$$L_d = \phi \sigma_s / 4 \tau_{bd} = k_d \phi \dots\dots\dots 5.4.1$$

- Where  $\phi$  = nominal diameter of the bar
- $\sigma_s$  = stress in bar at the section considered at design load
- $k_d$  = development length factor =  $\sigma_s / 4 \tau_{bd}$

**Note :** The development length includes the anchorage values of hooks in tension reinforcement

Taking  $\sigma_s = 0.87 f_y$  at the collapse stage,  $k_d = 0.87 f_y / 4 \tau_{bd} \dots\dots\dots 5.4.2$

For bars in compression, the value of  $\tau_{bd}$  given in table 1.1 are to be increased by 25%. Hence developed length ( $L_{dc}$ ) for bars in copressio is given by

$$L_{ds} = \phi \sigma_{sc} / 5 \tau_{bd} \dots\dots\dots 5.4.3$$

Hence the values of  $k_d$  for bars in compression will be  $=0.87 f_y/5 \tau_{bd}$

Table 6.2 gives the values of development length factor for various grades of concrete and the various grades of steel, both in tension as well as compression. The values have been rounded-off to the higher side.

**TABLE 6.2- VALUES OF DEVELOPMENT LENGTH FACTOR**

Grade of concrete	M 20			M 25		
	Fe 250	Fe 415	Fe 500	Fe 250	Fe 415	Fe 500
Bars in tension	46	47	57	39	41	49
Bars in comp.	37	38	46	31	33	39

Grade of concrete	M30			M35			M40		
	Fe 250	Fe 415	Fe 500	Fe 250	Fe 415	Fe 500	Fe 250	Fe 415	Fe 500
Bars in tension	37	38	46	32	34	40	29	30	36
Bars in comp.	29	31	37	26	27	32	23	24	29

**Note :** When the actual reinforcement provided is more than that theoretically required, so that the actual stress ( $\sigma_s$ ) in steel is less than the full design stress ( $0.87 f_y$ ), the development length required may be reduced by the following relation :

$$\text{Reduced development length } L_{dr} = L_d (A_{st \text{ required}} \div A_{st \text{ provided}})$$

This principle is used in the design of footing and other short bending members where bond is critical. By providing more steel, the bond requirements are satisfied.

**Bars bundled in contact :** The development length of each bar bundled bars shall be that for the individual by 10% for two bars in contact, 20% for three bars in contact and 33% for four bars in contact.

## 5.5 STANDARD HOOKS & BENDS FOR END ANCHORAGE ANCHORAGE LENGTH

The development length required at the end of a bar is known as *anchorage length*. However, in the case of development length, the force in the bar is developed by transfer of force from concrete to steel, while in the case of anchorage length, there is dissipation of force from steel to concrete.

Quite often, space available at the end of beam is limited to accommodate the full development length  $L_d$ . In that case, hooks or bends are provided. The anchorage value ( $L_a$ ) of hooks or bend is accounted as contribution to the development length  $L_d$ .

Fig. 5.5 (ai) shows a semi-circular hook, fully dimensioned, with respect to a factor  $K$ . The value of  $K$  is taken as 2 in the case of mild steel conforming to IS : 432-1966, (specifications for Mild-Steel and Medium Tensile Steel bars and Hard-Drawn steel wires for concrete reinforcement) or IS : 1139-1959, (specifications for 'Hot rolled mild steel and medium tensile steel deformed bars for concrete reinforcement'). The hook with  $K = 2$  is shown in Fig. 5.5 (a(ii)) with equivalent horizontal length of the hook. For the case of Medium Tensile Steel conforming to IS : 432-1966 or IS : 1139-1959,  $K$  is taken as 3. In the case of cold worked steel conforming to IS : 1986-1961, (specifications for cold twisted steel bars for concrete reinforcement),  $K$  is taken as 4. In the case of bars above 25 mm, however, it is desirable to increase the value of  $K$  to 3, 4 and 6 respectively.

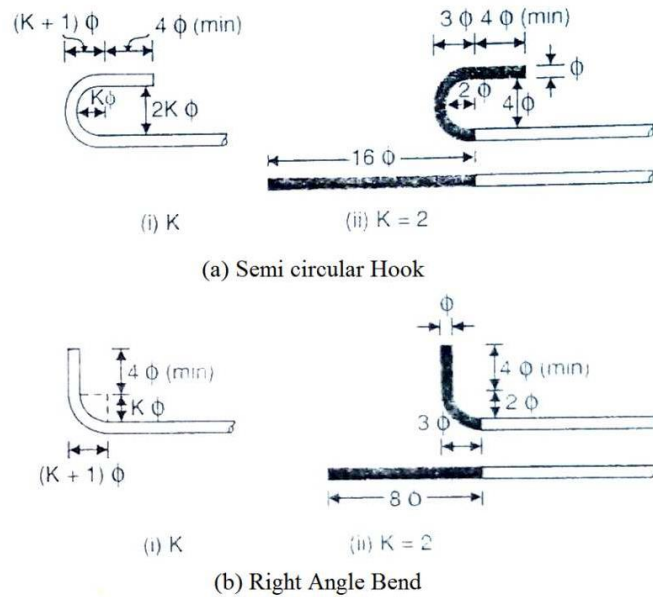

FIG- 5.5

Fig- 5.5 shows a right angled bend, with dimensions in terms of  $K$ , the value of which may be taken as 2 for ordinary mild steel for diameters below 25 mm and 3 for diameters above 25 mm.

In the case of deformed bars, the value of bond stress for various grades of concrete is greater by 60% than the plane bars. Hence deformed bars may be used without hooks, provided anchorage requirements are adequately met with.

## 5.6 CODE REQUIREMENTS FOR ANCHORING REINFORCING BARS (IS 456 : 2000)

- (i) **Anchoring Bars in Tension :-** Deformed bars may be used without end anchorages provided development length required is satisfied. Hooks should normally be provided for plain bars in tension. The anchorage value of bend shall be taken as 4 times the diameter of the bar for each  $45^\circ$  bend subject to a maximum of 16 times the diameter of the bar. The anchorage value of a standard U-type hook shall be equal to 16 times the diameter of the bar.
- (ii) **Anchoring Bars in Compression :-** The anchorage length of straight bar in compression shall be equal to the development length of bars in compression. The projected length of



hooks, bends and straight lengths beyond bends if provided for a bar in compression, shall be considered for development length.

**(iii) Anchoring Shear Reinforcement :-**

**Inclined bars :-** The developments length shall be as for bars in tension ; this length shall be measured as under : (1) in tension zone from the end of the sloping or inclined portion of the bar and (2) in the compression zone, from mid depth of the beam.

**Stirrups :-** Notwithstanding any of the provisions of this standard, in case of secondary reinforcement , such as stirrups and traverse ties, complete development lengths and anchorage shall be deemed to have been provided when the bar is bent through an angle of atleast 90° round a bar of atleast its own diameter and is continued beyond the end of the curve for a length of atleast eight diameters, or when the bar is bent through an angle of 135° and is continued beyond the end of curve for a length of atleast six bar diameters or when the bar is bent through an angle of 180° and is continued beyond the end of the curve for a length atleast four bar diameters.

**5.7 CHECKING DEVELOPMENTS LENGTH OF TENSION BARS :-**

As stated earlier, the computed stress ( $\sigma_s$ ) in a reinforcing bar, at every section must be developments on both the sides of section. This is done by providing development length  $L_d$  to both sides of the section. Such a developments length is usually available at mid-span location where positive (or sagging) B.M. is maximum for simply supported beams. Similarly, such a developments length is usually available at the intermediate support of a continuous beam where negative (or hogging) B.M. is maximum. Hence no special checking may be necessary in such locations. However special checking for developments length is essential at the following locations :

1. At simple supports
2. At cantilever supports
3. In flexural members that have relatively short spans
4. At points of contraflexure
5. At lap splices
6. At points of bar cutoff
7. For stirrups and transverse ties.

**5.8.DEVELOPMENTS LENGTH REQUIREMENTS AT SIMPLE SUPPORTS :  
DIAMETER OF REINFORCING BARS :-**

The code stipulates that at the simple supports (and at the point of inflection), the positive moment tension reinforcement shall be limited to a diameter such that

$$L_d \leq M_1/V + L_o \dots\dots\dots 5.8.1$$

Where  $L_d$  = developments length computed for design stress  $f_{yd}$  (=0.87  $f_y$ ) from Eq<sup>n</sup>

$M_1$ = Moments resistance of the section assuming all reinforcement at the section to be stressed to  $f_{yd}$ (= 0.87  $f_y$ )

$V$  = Shear force at the section due to design loads

$L_o$  = sum of anchorage beyond the centre of supports and the equivalent anchorage value of any hook or mechanical anchorage at the simple support ( At the point of inflexion,  $L_o$  is limited to  $d$  or  $12\phi$  which ever is greater).

The code further recommends that the value of  $M_1/V$  in eq<sup>n</sup> - 5.8.1 may be increased by 30% when the ends of the reinforcement are confined by a compressive reaction. This condition of confinement of reinforcing bars may not be available at all the types of simple supports.

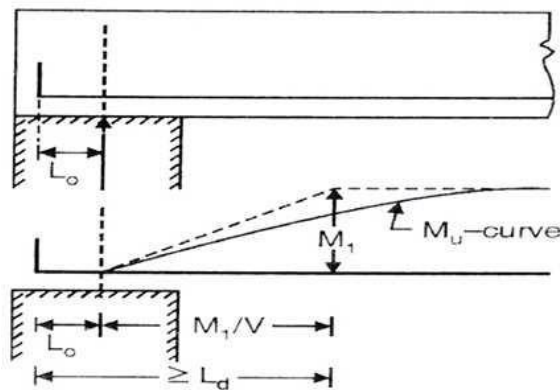

FIG-5.8.1

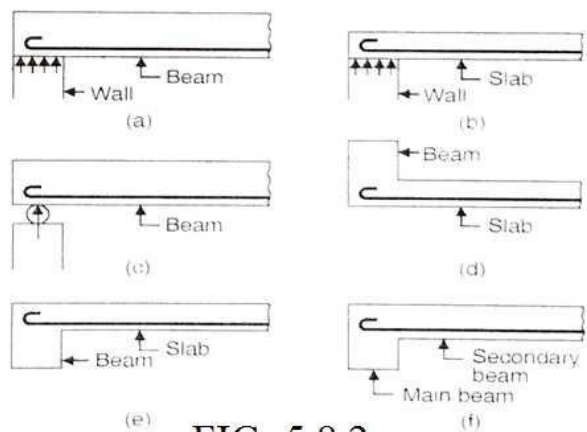

FIG- 5.8.2

Four type of simple supports are shown in fig-5.8.2. In fig- 5.8.2 (a) , the beam is simply supported on a wall which offers a compressive reaction which confines the ends of reinforcement. Hence a factor 1.3 will be applicable. However in fig-5.8.1 (c) and (d) though a simple support is available , the reaction does not confine the ends of the reinforcement, hence the factor 1.3 will not be applicable with  $M_1/V$  term. Similarly for the case of a slab connected to a beam Fig- 5.8.2(e) or for the case of secondary beam connected to a main beam [Fig-5.8.2(f)]

Tensile reaction is induced and hence a factor 1.3 will not be available.

Thus at simple supports where the compressive reaction confines the ends of reinforcing bars we have

$$L_d \leq 1.3 M_1/V + L_o \dots\dots\dots 5.8.2$$

**Computation of the Moment of Resistance  $M_1$  of bars available at supports:**

In eqn 5.8.1 ,  $M_1$  = Moment of Resistance of the section corresponding to the area of steel ( $A_{st}$ ) continued into the support and stressed to design stress equal to design stress equal to  $0.87f_y$ .

$$M_1 = 0.87f_y \cdot A_{st} (d - 0.416 X_u) \dots\dots\dots 5.8.3$$

$$\text{Where } X_u = 0.87f_y \cdot A_{st} / 0.36f_{ck} b \dots\dots\dots 5.83(a)$$

**Computation of Length (L<sub>0</sub>) :**

For the computation of L<sub>0</sub> , the support width should be known. Fig- 5.8.3 (a) and (b) show a beam with end support with a standard hook and 90° bend respectively.

Let X be the side cover to the hook ( Or bend) and X<sub>0</sub> be the distance of the beginning of the hook ( Or Bend) from the center line of the support ( Or Bend).

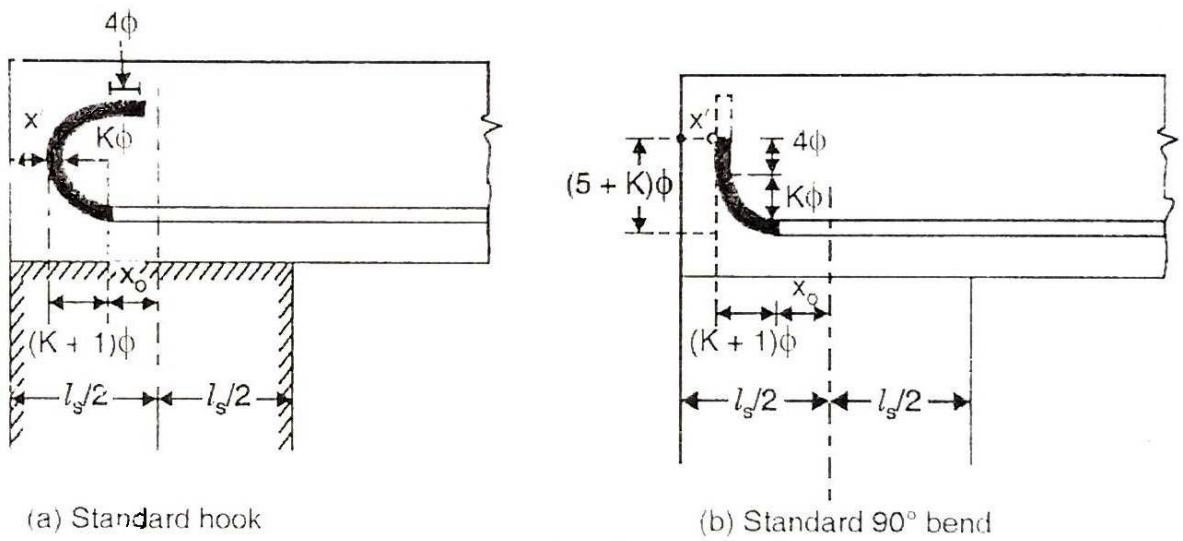

FIG. 5.8.3 COMPUTATION OF L<sub>0</sub>

(a) **Case-I : Standard Hook at the end [Fig-5.8.3(a)]:-** The dark portion shows the hook which has an anchorage value of 163 ( IS 456: 2000) for all types of steel. The distance of the beginning of the hook from its apex of the semi circle is equal to (K+1)3 . For mild steel bars K=2 and for HYSD bars, K=4, Hence the distance 3 for mild steel and 53 for HYSD bars. Let l be the width of the support.

$$\begin{aligned} \text{Then} \quad L_0 &= x_0 + 16 \phi \quad \text{where} \quad x_0 = \frac{l_s}{2} - x' - (K + 1) \phi \\ \therefore L_0 &= \left( \frac{l_s}{2} - x' - (K + 1) \phi \right) + 16 \phi = \frac{l_s}{2} - x' + (15 - K) \phi \quad \dots\dots 5.84 \end{aligned}$$

$$\text{Taking } K = 2 \text{ for mild steel bars, } L_0 = \frac{l_s}{2} - x' + 13 \phi \quad \dots\dots 5.84(a)$$

$$\text{Taking } K = 4 \text{ for HYSD bars, } L_0 = \frac{l_s}{2} - x' + 11 \phi \quad \dots\dots 5.84(b)$$

**(b) Case 2 : 90° standard bend** (Fig. 8.7 b) : The dark portion shows the 90° bend which has an anchorage value of  $8 \phi$  (IS 456 : 2000) for all types of steel. Here also, the distance of beginning of the hook from its apex of the semi-circle is equal to  $(K + 1) \phi$ .

$$\begin{aligned} \text{Then} \quad L_0 &= x_0 + 8 \phi \quad \text{where} \quad x_0 = \frac{l_s}{2} - x' - (K + 1) \phi \\ \therefore L_0 &= \left( \frac{l_s}{2} - x' - (K + 1) \phi \right) + 8 \phi = \frac{l_s}{2} - x' + (7 - K) \phi \quad \dots 5.8.5 \end{aligned}$$

$$\text{Taking } K = 2 \text{ for mild steel bars, } L_0 = \frac{l_s}{2} - x' + 5 \phi \quad \dots 5.8.5(a)$$

$$\text{Taking } K = 4 \text{ for HYSD bars } L_0 = \frac{l_s}{2} - x' + 3 \phi \quad \dots 5.8.5(b)$$

**Remedies to get development length** : If the check for the satisfaction of Eq. 5.8.1 is not obtained, following remedial measures may be adopted to satisfy the check .

1. Reduce the diameter  $\phi$  of the bar, thereby reducing the value of  $L_d$ , keeping the area of steel at the section unchanged. This is the standard procedure envisaged in the Code, i.e. reducing the value of  $L_d$  by *limiting* the diameter of the bar to such a value that Eq. 8.6 is satisfied.

2. Increasing the value of  $L_0$  by providing *extra length* of the bend over and above the standard value  $(5 + K) \phi$  shown by dotted lines in Fig. 5.8.2 (b).

3. By increasing the number of bars (there by increasing  $A_{st1}$ ) to be taken into the support. This method is uneconomical.

4. By providing adequate mechanical anchorage.

We shall discuss the first remedial method in the following section.

### CONDITIONS FOR CURTAILMENT OF REINFORCEMENT

In most of the cases, the B.M. varies appreciably along the span of the beam. From the point of view of economy, the moment of resistance of the beam should be reduced along the span according to the variation of B.M. This is effectively achieved by reducing the area of reinforcement, i.e. by curtailing the reinforcement provided for maximum B.M. In general, all steel, whether in tension or in compression, should extend  $d$  or  $12 \phi$  (whichever is greater) beyond the theoretical point of cut off (TPC).

#### Conditions for termination of tension reinforcement in flexural members:

Curtailment of Flexural tension reinforcement results in the loss of shear strength in the region of cutoff and hence it is necessary to make provision to guard against such loss. Flexural reinforcement shall not be terminated in a tension zone unless any one of the following condition is satisfied.

(a) The shear at the cutoff point does not exceed two thirds that permitted, including the shear strength of web reinforcement. In other words, the total *shear capacity* shall be atleast 1.5 times the applied shear at the point of curtailment, thus

$$V_u \leq \frac{2}{3} (V_{uc} + V_{us}) \quad \text{or} \quad V_{uc} + V_{us} \geq 1.5 V_u$$

Where  $V_{uc}$  = shear capacity of concrete, based on continuing reinforcement only.

$V_{us}$  = shear capacity of shear reinforcement

$V_u$  = applied shear at the point of curtailment.

(b) Stirrup area in excess of that required for shear and torsion is provided along each terminated bar over a distance from cutoff point equal to three fourth the effective depth of the member. Excess area of shear reinforcement is given by :

$$\text{Excess} \quad A_{sv} \geq \frac{0.4 b s_v}{f_y}$$

where

$$s_v \leq \frac{d}{8 \beta_b} \leq \frac{0.87 f_y A_{sv}}{0.4 b}$$

$$\beta_b = \frac{\text{area of bars cutoff at the section}}{\text{total area of bars at the section}}$$

(c) For 36 mm or smaller bars, the continuing bars provide double the area required for flexure at the cutoff point and the shear does not exceed three fourth that permitted.

$$\text{Thus,} \quad M_{ur} \geq 2 M_u$$

and

$$V_{uc} + V_{us} \geq 1.33 V_u$$

where

$M_{ur}$  = moment of resistance of remaining (or continued) bars

$M_u$  = B.M. at cutoff point ;  $V_u$  = S.F. at cutoff point

**5.9 DEVELOPMENT LENGTH AT POINT OF INFLEXION**

Fig. 8.8 shows the conditions at a point of inflection (P.I.) As already indicated in § 8.11, the Code states that the following condition be satisfied

$$\left( \frac{M_1}{V} + L_0 \right) \geq L_d \quad \dots\dots 5.9.1$$

where  $L_0$  should not be greater than  $d$  or  $12 \phi$  whichever is greater, and  $V$  is the shear force at the point of inflection.

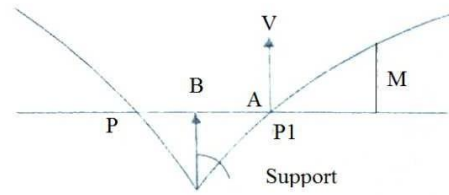

FIG. 5.9 DEVELOPMENT LENGTH AT A POINT OF INFLECTION

**5.10 SPLICING:**

(a) The purpose of splicing is to transfer effectively the axial force from the terminating bar to the connecting bar with the same line of action at the junction. [Fig-5.10 (a)].

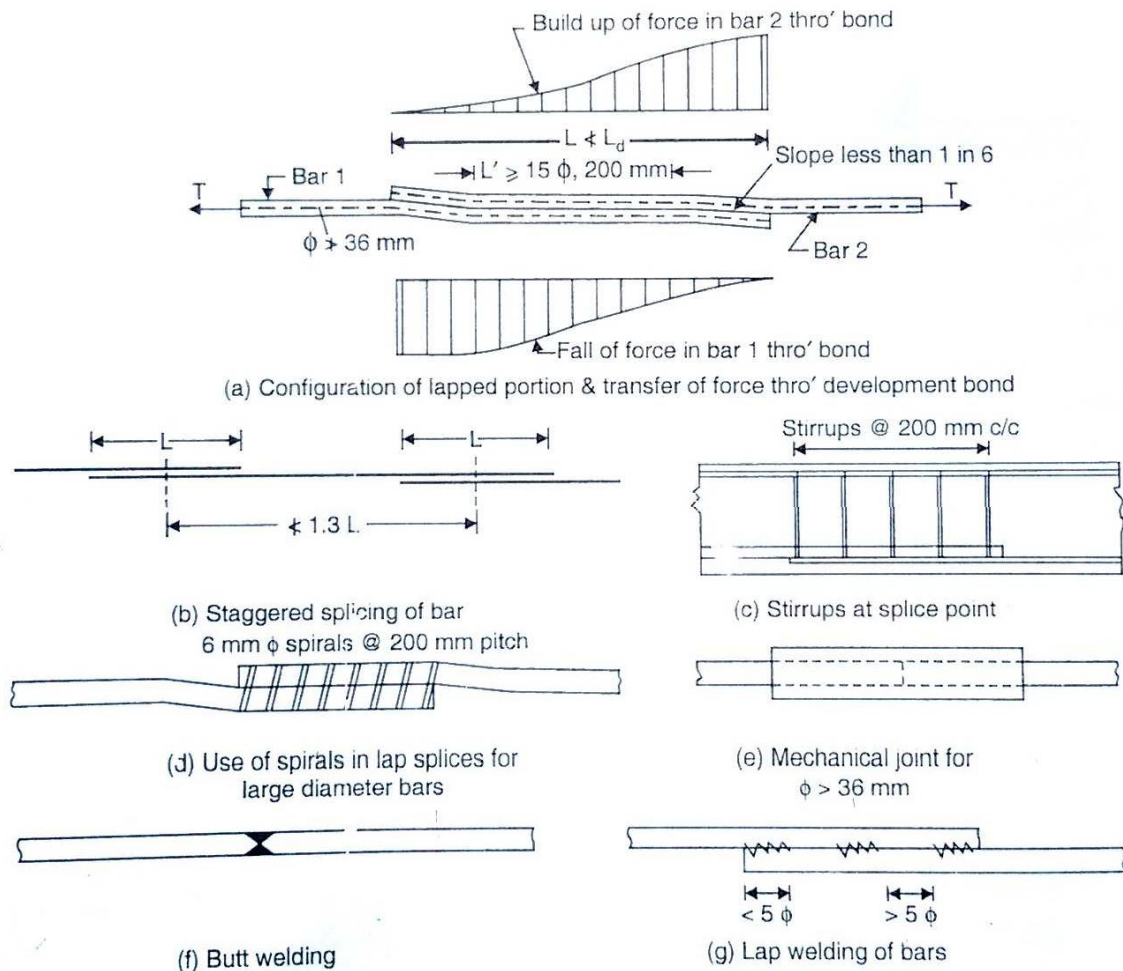

FIG- 5.10 REINFORCEMENT SPLICING

Slicing of a bar is essential in the field due to either the requirements of construction or non availability of bars of desired length. The Figures given are as per the recommendation of the IS 456 : 2000.

(a) Lap splices shall not be used for bars larger than 36 mm. For larger diameters bars may be weld. In case where welding is not practicable , lapping of bars larger than 36mm may be permitted, in which case additional spiral should be provided around the lapped bars [Fig-5.10(d)].

(b) Lap splices shall be considered as staggered if the centre to centre distance of the splices is not less than 1.3 times the lap length calculated as described in (c).

(c) The lap length including anchorage value of hooks for bars in *flexural tension shall be  $L_d$  or  $30 \phi$*  whichever is greater and for *direct tension shall be  $2 L_d$  or  $30 \phi$*  whichever is greater. The *straight length ( $L'$ )* of the lap shall not be less than  $15 \phi$  or 200 mm (Fig. 5.10 [a]) The following provisions shall also apply :

(1) Top of a section as cast and the minimum cover is less than twice the diameter of the lapper bar, the lapped length shall be increased by a factor of 1.4.

(2) Corner of a section and minimum cover to either face is less than twice the diameter of the lapped bar or where the clear distance between adjacent laps is less than 75 mm or 6 times the diameter of lapper bar, whichever is greater, the lap length should be increased by a factor of 1.4.

Where both conditions (1) and (2) apply , the lap length should be increased by a factor of 2.0.

*Note* : Splices in tension members shall be enclosed in spirals made of bars not less than 6 mm diameter with pitch not more than 100 mm.

(d) The lap length in compression shall be equal to the development length in compression, but not less than  $24 \phi$ .

(e) When bars of two different diameter are to be spliced, the lap length shall be calculated on the basis of diameter of the smaller bar.

(f) When splicing of welded wire fabric is to carried out, lap splices of wires shall be made so that overlap measured between the extreme cross wires shall be not less than spacing of cross wires plus 100 mm.

(g) In case of bundled bars, lapped splices of bundled bars shall be made by splicing one bar at a time : such individual splices within a bundle shall be staggered.

### **Strength of Welds :**

The following values may be used where the strength of weld has been proved by tests to be at least as great as that of the parent bars.

#### **(a) Splices in compression:**

For welded splices and mechanical connection, 100 percent of the design strength of joined bars.

#### **(b) Splices in tension:**

(1) 80% of the design strength of welded bars ( 100% if welding is strictly supervised and if at any c/s of the member not more than 20% of the tensile reinforcement is welded)

(2) 100% of the design strength of mechanical connection.

**End Bearing Splices:** End bearing splices should be used only for bars in compression. These are of square cut and concentric bearing ensured by suitable devices.

**EXAMPLE-6.1**

A SIMPLY SUPPORTED IS 25 cm X50cm and has 2 – 20 mm TOR bars going into the support. If the shear force at the center of the support is 110 KN at working loads, determine the anchorage length. assume M20 mix and Fe 415 grade TOR steel .

**Solution:-**

For a load factor equal to 1.5, the factored SF= 1.5 x 110=165 kN.

Assuming 25 mm clear cover to the longitudinal bars

Effective depth = 500- 25 – 20/2 = 465 mm.

Characteristic strength of TOR steel  $\sigma_y = 415 \text{ N/mm}^2$

Moment of resistance  $M_1 = 0.87 \sigma_y A_t (d - 0.42 x)$

$$x = \frac{0.87 \sigma_y A_t}{0.36 \sigma_{ck} b} = \frac{0.87 \times 415 \times 628}{0.36 \times 20 \times 250} = 126 \text{ mm} < x_m \quad \text{OK}$$

or  $M_1 = 0.87 \times 415 \times 2 \times \pi/4 \times 20^2 (465 - 0.42 \times 126) = 93.45 \times 10^6 \text{ Nmm}$

Bond stress  $\tau_{bd} = 1.2 \text{ N/mm}^2$  for M20 mix. It can be increased by 60% in case of TOR bars.

$$\text{Development length } L_d = \frac{\phi \sigma_s}{4 \tau_{bd}} = \frac{0.87 \times 415 \phi}{4 \times (1.6 \times 1.2)} = 47 \phi$$

If the bar is given a 90° bend at the centre of support, its anchorage value

$$L_o = 8 \phi = 8 \times 20 = 160 \text{ mm}$$

$$L_d \leq 1.3 M_1/V + L_o$$

$$47 \phi \leq \left[ \frac{1.3 \times 93.45 \times 10^6}{165 \times 1000} \right] + 160$$

or,  $\phi \leq 19 \text{ mm}$



Since actual bar diameter of 20 mm is greater than 19 mm, there is a need to increase the anchorage length. Let us increase the anchorage length  $L_o$  to 240 mm. It gives

$$\phi \leq 20.8 \text{ mm} \quad \text{OK}$$

The arrangement of 90° bend is shown in Fig. 8.19a.

*Alternatively*

Provide a U bend at the centre of support, its anchorage value,

$$L_o = 16 \phi = 320 \text{ mm}$$

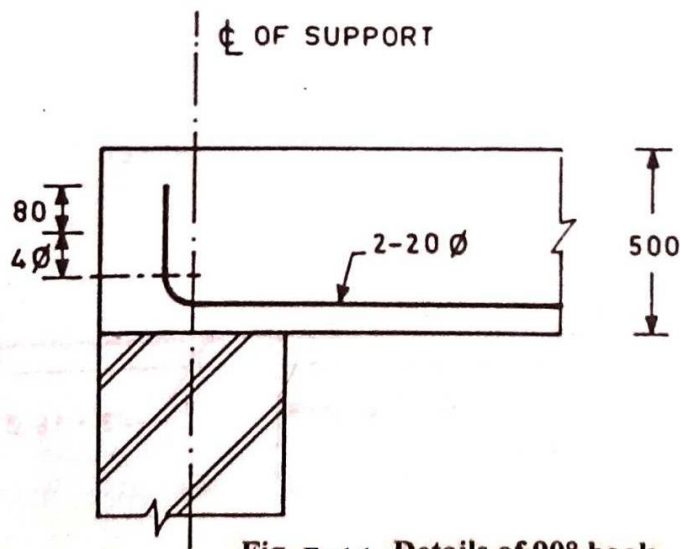

**Fig. Ex 1.1 Details of 90° hook**

$$L_d \leq 1.3 M_1/V + L_o.$$

$$47\phi \leq \left[ \frac{1.3 \times 93.45 \times 10^6}{165 \times 1000} \right] + 320$$

$$\text{Or. } \phi \leq 22.47 \text{ mm}$$

Actual bar diameter provided is 20 mm < 22.47 mm.

The arrangement of U- Bend is shown in Fig-Ex 1.2.

In High strength reinforced bars U- Bend should be avoided as far as possible since they may be brittle and may fracture with bending.

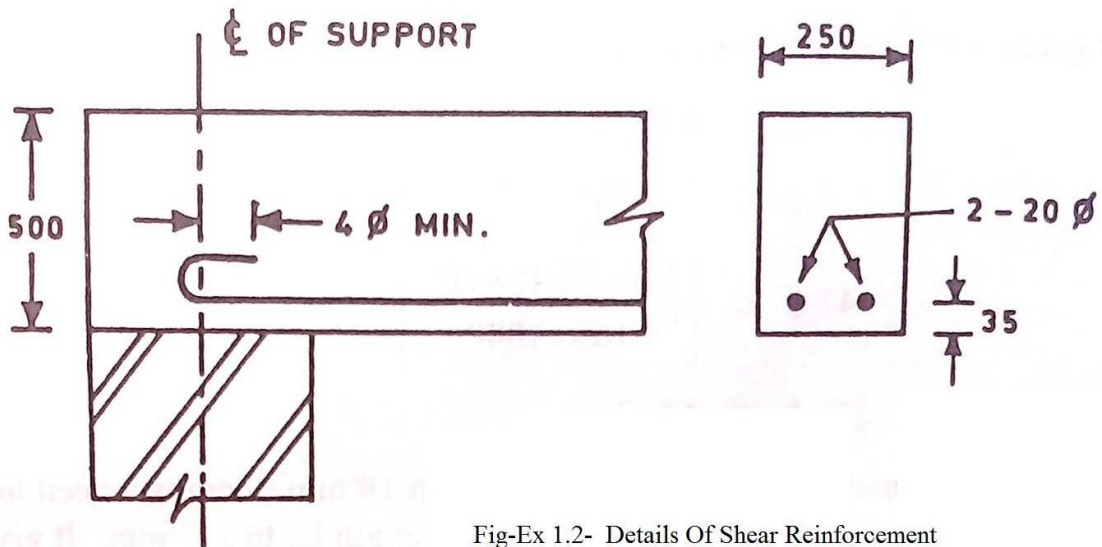

### Example 5.2:

A continuous beam 25 cm X 40 cm carries 3-16 mm longitudinal bars beyond the point of inflection in the sagging moment region as shown in Fig.Ex 1.3,.If the factored SF at the point of inflection is 150 kN,  $a_{ck} = 20 \text{ N/mm}^2$  and  $a_y = 415 \text{ N/mm}^2$ , check if the beam is safe in bond ?

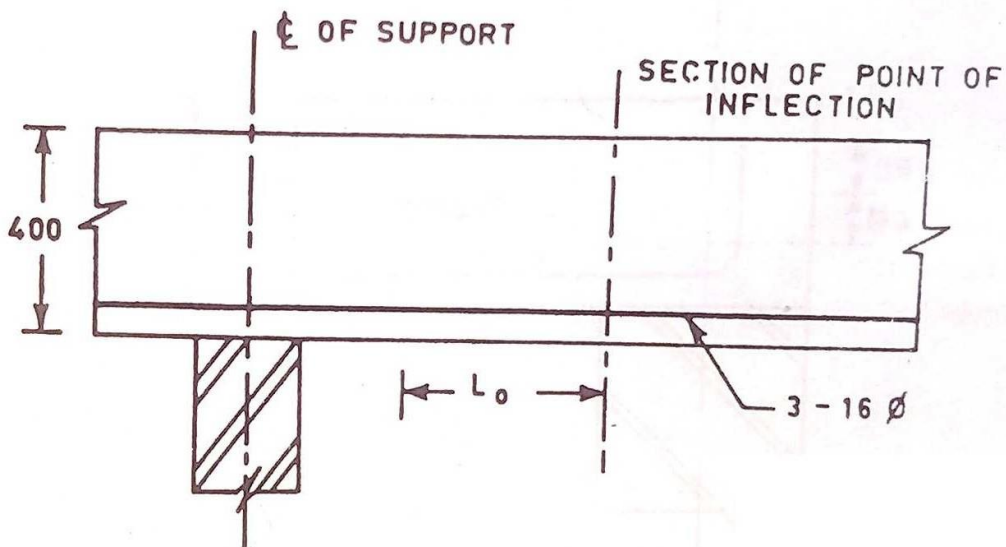

$$\text{Depth of neutral axis } x = \frac{0.87 \sigma_y A_t}{0.36 \sigma_{ck} b} = \frac{0.87 \times 415 \times 3 \times \pi / 4 \times 16^2}{0.36 \times 20 \times 250}$$

$$= 120 \text{ mm} < x_m (= 0.48 d) \quad \text{OK}$$

$$\begin{aligned} \text{Moment of resistance } M_1 &= 0.87 \sigma_y A_t (d - 0.42 x) \\ &= 0.87 \times 415 \times 603 (367 - 0.42 \times 120) = 68.90 \times 10^6 \text{ Nmm} \end{aligned}$$

$$\text{Development length } L_d = \frac{\sigma_s \phi}{4 \tau_{bd}}$$

$$\text{Bond stress } \tau_{bd} = 1.6 \times 1.2 \text{ N/mm}^2 \text{ for M20 mix and HSD steel}$$

$$\text{or } L_d = \frac{0.87 \times 415 \phi}{4 \times 1.6 \times 1.2} = 47 \phi$$

$$\text{Anchorage length } L_o = \text{greater of } d \text{ or } 12 \phi$$

$$= \text{greater of } 367 \text{ mm, or } 12 \times 16 = 192 \text{ mm}$$

$$= 367 \text{ mm}$$

$$L_d \leq \frac{M_1}{V} + L_o$$

$$\text{or } 47 \phi \leq \frac{68.9 \times 10^6}{150 \times 1000} + 367 \quad \text{or, } \phi \leq 17.6 \text{ mm}$$

Thus, 16 mm bars are safe in bond at the point of inflection.

## CHAPTER 06

### ANALYSIS AND DESIGN OF T-BEAM IN LIMIT STATE METHOD

#### **Beams (LSM)**

7.1 Control of deflection and ensuring lateral stability in beams as per Clause 23.2 & 23.3 of IS-456.

7.2 Design of singly reinforced rectangular beams, Design of doubly reinforced beams as per IS 456/SP-16 for bending and shear

Design of T beams as per IS 456 for bending and shear

#### **Course Objectives:**

7.1 Control of deflection and ensuring lateral stability in beams as per Clause 23.2 & 23.3 of IS-456.

#### **Introduction**

Structures designed by limit state of collapse are of comparatively smaller sections than those designed employing working stress method. They, therefore, must be checked for deflection and width of cracks. Excessive deflection of a structure or part thereof adversely affects the appearance and efficiency of the structure, finishes or partitions. Excessive cracking of concrete also seriously affects the appearance and durability of the structure. Accordingly, cl. 35.1.1 of IS 456 stipulates that the designer should consider all relevant limit states to ensure an adequate degree of safety and serviceability. Clause 35.3 of IS 456 refers to the limit state of serviceability comprising deflection in cl. 35.3.1 and cracking in cl. 35.3.2. Concrete is said to be durable when it performs satisfactorily in the working environment during its anticipated exposure conditions during service. This lesson discusses about the different aspects of deflection of beams and the requirements as per IS 456. In addition, lateral stability of beams is also taken up while selecting the preliminary dimensions of beams.

#### **Short- and Long-term Deflections**

Short-term deflection refers to the immediate deflection after casting and application of partial or full service loads, while the long-term deflection occurs over a long period of time largely due to shrinkage and creep of the materials. The following factors influence the short-term deflection of structures:

- (a) magnitude and distribution of live loads,
- (b) span and type of end supports,
- (c) cross-sectional area of the members,
- (d) amount of steel reinforcement and the stress developed in the reinforcement,
- (e) characteristic strengths of concrete and steel, and
- (f) amount and extent of cracking

The long-term deflection is almost two to three times of the short-term deflection. The following are the major factors influencing the long-term deflection of the structures.

- (a) Humidity and temperature ranges during curing,
- (b) age of concrete at the time of loading, and
- (c) type and size of aggregates, water-cement ratio, amount of compression reinforcement, size of members etc., which influence the creep and shrinkage of concrete.

### **Control of deflection and ensuring lateral stability in beams as per Clause 23.2 & 23.3 of IS-456.**

Clause 23.2 of IS 456 stipulates the limiting deflections under two heads as given below:

- (a) The maximum final deflection should not normally exceed span/250 due to all loads including the effects of temperatures, creep and shrinkage and measured from the as-cast level of the supports of floors, roof and all other horizontal members.
- (b) The maximum deflection should not normally exceed the lesser of span/350 or 20 mm including the effects of temperature, creep and shrinkage occurring after erection of partitions and the application of finishes.

It is essential that both the requirements are to be fulfilled for every structure.

#### **Selection of Preliminary Dimensions :**

The two requirements of the deflection are checked after designing the members. However, the structural design has to be revised if it fails to satisfy any one of the two or both the requirements. In order to avoid this, IS 456 recommends the guidelines to assume the initial dimensions of the members which will generally satisfy the deflection limits. Clause 23.2.1 stipulates different span to effective depth ratios and cl. 23.3 recommends limiting slenderness of beams, a relation of  $b$  and  $d$  of the members, to ensure lateral stability. They are given below:

#### **(A) For the deflection requirements**

Different basic values of span to effective depth ratios for three different support conditions are prescribed for spans up to 10 m, which should be modified under any or all of the four different situations:

- (i) for spans above 10 m,
- (ii) depending on the amount and the stress of tension steel reinforcement,
- (iii) depending on the amount of compression reinforcement,
- (iv) for flanged beams.

#### **(B) For lateral stability as per clause 23.3 of IS-456**

The lateral stability of beams depends upon the slenderness ratio and the support conditions. Accordingly cl. 23.3 of IS code stipulates the following:

(i) For simply supported and continuous beams, the clear distance between the lateral restraints shall not exceed the lesser of  $60b$  or  $250b^2/d$ , where  $d$  is the effective depth and  $b$  is the breadth of the compression face midway between the lateral restraints.

(ii) For cantilever beams, the clear distance from the free end of the cantilever to the lateral restraint shall not exceed the lesser of  $25b$  or  $100b^2/d$ .

### Span/depth ratios and modification factors

Sl. No.	Items	Cantilever	Simply supported	Continuous
1	Basic values of span to effective depth ratio for spans up to 10 m	7	20	26
2	Modification factors for spans > 10 m	Not applicable as deflection calculations are to be done.	Multiply values of row 1 by 10/span in metres.	
3	Modification factors depending on area and stress of steel	Multiply values of row 1 or 2 with the modification factor from Fig.4 of IS 456.		
4	Modification factors depending as area of compression steel	Further multiply the earlier respective value with that obtained from Fig.5 of IS 456.		
5	Modification factors for flanged beams	(i) Modify values of row 1 or 2 as per Fig.6 of IS 456. Further modify as per row 3 and/or 4 where reinforcement percentage to be used on area of section equal to $b_f d_f$ .		

## 7.2 Design of singly reinforced rectangular beams, Design of doubly reinforced beams as per IS 456/SP-16 for bending and shear

### Design of singly reinforced rectangular beams as per IS 456/SP-16 for bending and shear

#### Types of Problems

Two types of problems are possible: (i) design type and (ii) analysis type.

In the design type of problems, the designer has to determine the dimensions  $b$ ,  $d$ ,  $D$ ,  $A_{st}$  and other detailing of reinforcement, grades of concrete and steel from the given design moment of the beam. In the analysis type of the problems, all the above data will be known and the designer has to find out the moment of resistance of the beam

#### Design of the singly reinforced beam for bending

Type 1 :To design a singly reinforced rectangular section for a given width and applied factored moment

$$d_{\text{bas}} = \sqrt{\frac{M_u}{Q_{\text{lim}} \times b}}$$

1. Assume 5% larger effective depth for  $d \leq 500$  mm & 10% larger depth for  $1000 \text{ mm} \geq d > 500$  mm
2. Assume one layer of 20mm diameter for (case 1) & two layers of 20mm diameter, bars (case 2)
3. If the clear cover to main reinf is 30mm Effective cover = 30+10 (Assume 1 – Layer  $20\phi$ ) = 40 mm  
=40+20 (Assume 2 Layers  $20\phi$ )
4. Overall depth  $D$  over all =  $d+40$   $D$  over all =  $d+60$
5. Now  $d = D$  overall – 40mm (case1)  
 $D$  overall – 60 mm (case-2)
6. Determine  $\frac{M_u}{bd^2}$ ,  $p_t$ ,  $A_{st}$ ,  $A_{st\text{lim}}$
7. Select the bar size and number such that  $A_{st} > A_{st\text{required}}$  & also  $A_{st} < A_{st\text{lim}}$

**Type 2** :- To find the steel area for a given factored moment

We know  $d_{\text{bas}} = \sqrt{\frac{M_u}{Q_{\text{lim}} \times b}}$  (Assume b)

For a given factored moment, width & depth of Section,final

$$m_{\text{ulim}} = Q_{\text{lim}} \times b d^2$$

$M_u < M_{\text{ulim}}$ , design as under reinforced Section

$M_u = M_{\text{ulim}}$ , design as balanced Section

$M_u > M_{\text{ulim}}$ , design as doubly reinforced Section

## **Design of the singly reinforced beam for shear**

### **Shear reinforced In beams**

The shear reinforcement shall be provided by the reinforcement which cross the cracks. These shear reinforcement. minimize the size of diagonal tension crack & carry diagonal tension stress from one side of crack to the other. The provision of shear reinforcement is made by the following forms.

- (i) Vertical Stirrups
- (ii) Inclined Stirrups
- (iii) Bent up bars along with Stirrups

## Design for Shear

1. Find the Maximum S.F
2. Find the factored S.F ( $V_u$ )
3. Find the nominal shear stress  $v_v = \frac{V_u}{bd}$
4. Obtain the design shear strength of concrete corresponding to percentage of tensile reinforcement provided for flexure from table 19, pg-73 IS 456.

Design shear strength ( $v_c$ ) :- It is the capacity of concrete along with tensile reinforcement. To take the amount of shear force without providing any reinforcement for shear.

5. Find the excess shear force for which shear reinforcement is required to be provided i.e.  $V_{us}$ .  $V_{us} = \text{Applied shear} - \text{shear force to be resisted by concrete without any shear reinforcement.}$   
 $V_{uc} = V_u - v_c bd$
6. To determine the quantity of shear reinforcement in terms of stirrup spacing as under.

(i) For vertical stirrups

$$(ii) V_{uc} = \frac{0.87 f_y A_{sv} \times d}{S_v}$$

$V_{us}$  = Excess S.F to be resisted

$A_{sv}$  = Area of shear reinforcement.

$S_v$  = Spacing of stirrups

$$S_v = \frac{0.87 f_y A_{sv}}{d} V_{us}$$

(iii) For inclined stirrups

$$V_{uc} = \frac{0.87 f_y A_{sv} \times d (\sin \alpha + \cos \alpha)}{S_v}$$

Or

$$S_v = \frac{0.87 f_y A_{sv} d (\sin \alpha + \cos \alpha)}{V_{uc}}$$

(iv) For Bent up bars

$$V_{uc} = 0.87 f_y A_{sv} \cdot \sin \alpha$$

IS 456 says the contribution of bent up bars towards shear resistance shall not exceed half of the shear resistance.

$\alpha$  = angle between bent up the inclined stirrups or bent up bar and total axis of member not less than  $45^\circ$



Minimum shear reinforcement .

Spacing of shear stirrups should not exceed the following.

$$\frac{A_{sv}}{bS_v} \geq \frac{0.4}{0.87 f_y}$$

$$(i) S_v = \frac{0.87 f_y A_{cv}}{0.4 b}$$

(ii) 0.75 d ( d = Effective depth)

(iii) 300 mm c/c distance

### Example 1

A simply supported rectangular beam of 4 m span carries a uniformly distributed characteristic load including self-weight of 20 kN/m. The beam section is 230 mm x 450 mm overall. Design the beam for bending and shear. The materials are grade M20 concrete and HYSD reinforcement of grade Fe 415. The beam is suspended from the upper floor level.

PG 356 fig 9.5

Solution:

$$P_u = 1.5 \times 20 = 30 \text{ kN/m}$$

$$M_{u,max} = 30 \times \frac{4^2}{8} = 60 \text{ kNm and } V_{u,max} = 30 \times \frac{4}{2} = 60 \text{ kN.}$$

(a) Moment steel

The section is 230 mm x 450 mm overall. Assuming one layer of 16 mm diameter bars, effective depth shall be

$$d = 450 - 30(\text{cover}) - 8 (\text{centre of reinforcement}) = 412 \text{ mm.}$$

Depth required for singly reinforced section

$$= \sqrt{\frac{60 \times 10^6}{2.76 \times 230}}$$

$$= 308 \text{ mm} < 412 \text{ mm}$$

∴ Design as singly reinforced section.

$$\frac{M_u}{bd^2} = \frac{60 \times 10^6}{230 \times 412 \times 412} = 1.54$$

From SP 16 table no 2  $P_t = 0.474$

$$A_{ct} = \frac{0.474 \times 230 \times 412}{100} = 449 \text{ mm}^2$$

Minimum steel required

$$A_c = \frac{0.205}{100} \times 230 \times 412 = 194 \text{ mm}^2$$

$$A_{\text{cbs}} = \frac{0.96}{100} \times 230 \times 412 = 910 \text{ mm}^2$$

$$\therefore 194 \text{ mm}^2 < A_{\text{st, provided}} < 910 \text{ mm}^2.$$

Provide 4 no. 12mm # = 4x113 = 452 mm<sup>2</sup>

Let 2 bar be bent at 1.25 D

= 1.25 X 450 = 562.5 mm, say 600 mm, from the face of the support

Check for shear :

As support

$$V_u = 60 \text{ kN}$$

$$\tau_v = \frac{60 \times 10^3}{230 \times 412} = 0.633 \text{ N/mm}^2.$$

$$\frac{100 A_c}{bd} = \frac{2 \times 113 \times 100}{230 \times 412} = 0.238$$

$$\therefore \tau_c = 0.332 \text{ N/mm}^2 < 0.633 \text{ N/mm}^2.$$

∴ Shear design is necessary

Note that the critical section for checking the shear stress in this case is the face of the support (and not at distance d from the face of the support ) because the reaction at support induces tension in end region.

As support 2 bent bars can be used to carry shear stress. These give a shear resistance of

$$\sin 45^\circ \times 2 \times 113 \times 0.87 \times 415 \times 10^{-3} = 57.69 \text{ kN.}$$

$$\tau_c bd = 0.332 \times 230 \times 412 \times 10^{-3} = 31.46 \text{ kN.}$$

$$V_{\text{us}} = V_u - \tau_c bd = 60 - 31.46 = 28.54 \text{ kN.}$$

Bent bars share 50% = 14.27 kN.

Stirrups provide 50% = 14.27 kN.

Using 6 mm  $\phi$  two legged M.S. stirrups, spacing can be given by  $\frac{0.87 f_y A_{sv} d}{V_{uc}}$

Where  $A_{sv} = 2 \times 28 = 56 \text{ mm}^2$

$$\therefore S_v = \frac{0.87 \times 250 \times 56 \times 412}{14.27 \times 10^3} = 351 \text{ mm} \dots \dots \dots (1)$$

At distance of 550 mm from support, where two bars are bent

$$V_u = 60 - (0.55 \times 30) = 43.5 \text{ kN}$$

$$V_{us} = 43.5 - 31.46 = 12.04 \text{ kN}$$

This will give larger spacing than above.

Minimum shear reinforcement .

Spacing of shear stirrups should not exceed the following.

$$\frac{A_{sv}}{bS_v} \geq \frac{0.4}{0.87 f_y}$$

$$(i) S_v = \frac{0.87 f_y A_{cv}}{0.4 b}$$

(ii) 0.75 d ( d = Effective depth)

(iii) 300 mm c/c distance

$$\text{Using 2legged 6 mm } \phi \text{ mild steel stirrup } S_v = \frac{0.87 \times 250 \times 56}{0.4 \times 232} = 132.4 \text{ mm}$$

For 230 mm wide beam minimum shear reinforcement is 6 mm  $\phi$  about 130 mm c/c..... (2)

From (1) and (2) minimum shear reinforcement shall be provided, i.e., 6 mm  $\phi$  about 130 mm c/c.

### **Design of doubly reinforced beams as per IS 456/SP-16 for bending and shear**

#### **DOUBLY REINFORCEMENT BEAMS**

When the applied moment is greater than M.R of a singly reinforced section, then steel reinforcement is added in compression zone to increase the M.R of the section, then this is known as doubly reinforced section

There are three alternatives

- i. Increase the dimensions of the section i.e. depth
- ii. Higher grades of concrete can be increased to increase the M.R of the section.
- iii. Steel reinforcement. may be added in compression zone to increase the M.R of the section.

#### **Design of doubly reinforced beams**

Type -1: To find out reinforcement for flexure for a given section & factored moment.

- (i) Find out  $M_{u,lim}$  & reinforcement  $A_{st,lim}$  for a given section by using the equation

$$M_{u,lim} = Q_{lim} \times b d^2$$

$$= 0.36 f_{ck} b x_{u,NaS} (d - 0.42 x_{u,NaS})$$

$$\& A_{st,lim} = \frac{M_{u,lim}}{0.87 f_y (d - 0.42 x_{u,NaS})}$$

$$0.87 x A_{st} f_y (d - 0.42 x_{u,max})$$

- (ii) Obtain moment  $M_{u2} = M_u - M_{u,lim}$

- (iii) Find out compression steel from equation  $M_{u2} = A_{sc} (f_{cc} \cdot f_c) (d - d')$

Neglecting  $f_{cc}$ ,  $A_{cc} = \frac{M_{u2}}{f_{cc} (d - d_u)}$

- (iv) Corresponding  $A_{st}$  Tensile steel  $A_{st2}$  can be found out from

$$A_{ct2} = \frac{f_{cc} f_{cc}}{0.87 f_y}$$

$$(v) A_{ct} = A_{ct1} + A_{ct2}$$

- (vi) Provide the reinforcement

### Example 2

Design a simply supported rectangular beam of size 230 mm x 600 mm overall for a super-imposed load of 46 kN/m. Span of the beam is 5 m. The materials are M 20 grade concrete and HYSD reinforcement of grade Fe 415.

Solution:

Self weight of beam =  $0.3 \times 0.60 \times 25 = 3.45$  kN/m

Super-imposed load =  $\frac{46.00 \text{ kN/m}}{\text{Total } 49.45 \text{ kN/m}}$  say 50 kN/m

Factor load =  $1.5 \times 50 = 75$  kN/m

$$M_u = \frac{5^2}{8} \times 75 = 243.4 \text{ kNm}$$

$$V_u = \frac{5}{2} \times 75 = 187.5 \text{ kN}$$

Moment steel:

Assuming 2 layers of 20 mm diameter bars

$$D = 600 - 30 - 20 - 10 = 540 \text{ mm}$$

$$\frac{M_u}{bd^2} = \frac{243.4 \times 10^6}{230 \times 540^2} = 3.63 > 2.76$$

• Doubly reinforced section

$$M_{u,lim} = 2.76 \times 230 \times 540^2 \times 10^{-6} = 185.10 \text{ kNm}$$

$$M_{u2} = 243.4 - 185.10 = 58.3 \text{ kNm.}$$

Let the compression reinforcement be provided at an effective cover of 40 mm

$$\frac{d'}{d} = \frac{40}{545} = 0.07, \text{ consider } \frac{d'}{d} = 0.1$$

Stress in compression steel,  $f_{sc} = 353 \text{ N/mm}^2$  (refer to table f of S.P-16)

$$A_{cc} = \frac{Mu_2}{f_{cc}(d-d')} = \frac{58.3 \times 10^6}{353(540-40)} = 330 \text{ mm}^2$$

Corresponding tension steel

$$A_{ct2} = \frac{E_{cc} f_{cc}}{0.87 f_y} = \frac{330 \times 353}{0.87 \times 415} = 323 \text{ mm}^2$$

$$A_{st1} = A_{st,lim} = P_{t,lim} \times \frac{bd}{100}$$

$$= 0.96 \times \frac{230 \times 540}{100} = 1192 \text{ mm}^2$$

$$A_{st} = A_{st1} + A_{st2} = 1192 + 323 \text{ mm}^2 = 1515 \text{ mm}^2$$

$$A_{sc} = 2-16 \# = 402 \text{ mm}^2$$

$A_{st} = 5-20\# = 1570 \text{ mm}^2$  (all straight). Provide 3 bars in first layers and 2 bars in second layer.

For designed section, equating total compression and total tension

$$0.36 f_{ck} b x_u + A_{sc} f_{sc} = 0.87 f_y A_{st}$$

$$0.36 \times 20 \times 230 x_u + 402 \times 353 = 0.87 \times 415 \times 1570$$

$$x_u = 256.6 \text{ mm}$$

$$x_{u,max} = 0.48d = 0.48 \times 540 = 259.2 \text{ mm}$$

$$x_u < x_{u,max}$$

Hence the beam is under reinforced section.

(b) Check for shear:

$$v_v = \frac{187.5 \times 10^3}{230 \times 540} = 1.51 \text{ N/mm}^2 < 2.8 \text{ N/mm}^2$$

$$\frac{100 A_{sc}}{bd} = \frac{100 \times 402}{230 \times 540} = 1.26$$

$$v_c = 0.672 \text{ N/mm}^2$$

As the ends are confined with compressive reaction, shear at distance  $d$  will be used for checking shear at support. At 540 mm, shear is equal to

Using 8 mm # two legged stirrups, spacing can be given by  $\frac{0.87 f_y A_{sv} d}{V_{uc}}$

$$\text{Where } A_{sv} = 2 \times 50 = 100 \text{ mm}^2$$

$$\therefore S_v = \frac{0.87 \times 415 \times 100 \times 540}{63.5 \times 10^3} = 307 \text{ mm} \dots\dots\dots(1)$$

At distance of 550 mm from support, where two bars are bent

$$V_u = 187.5 - (0.540 \times 75) = 147 \text{ kN}$$

$$V_{us} = 147 - 0.672 \times 230 \times 540 \times 10^{-3} = 63.5 \text{ kN}$$

This will give larger spacing than above.

Minimum shear reinforcement .

Spacing of shear stirrups should not exceed the following.

$$\frac{A_{sv}}{bS_v} \geq \frac{0.4}{0.87 f_y}$$

$$(i) S_v = \frac{0.87 f_y A_{cv}}{0.4 b}$$

$$(ii) 0.75 d \text{ ( } d = \text{Effective depth)} = 0.75 \times 540 = 405 \text{ mm}$$

$$(iii) 300 \text{ mm c/c distance}$$

$$\text{Using 2legged 8 mm \# stirrup } S_v = \frac{0.87 \times 415 \times 100}{0.4 \times 230} = 392.4 \text{ mm}$$

For 230 mm wide beam minimum shear reinforcement is 8 mm # about 300 mm c/c ..... (2)

Hence provide mm # about 300 mm c/c through out the beam.

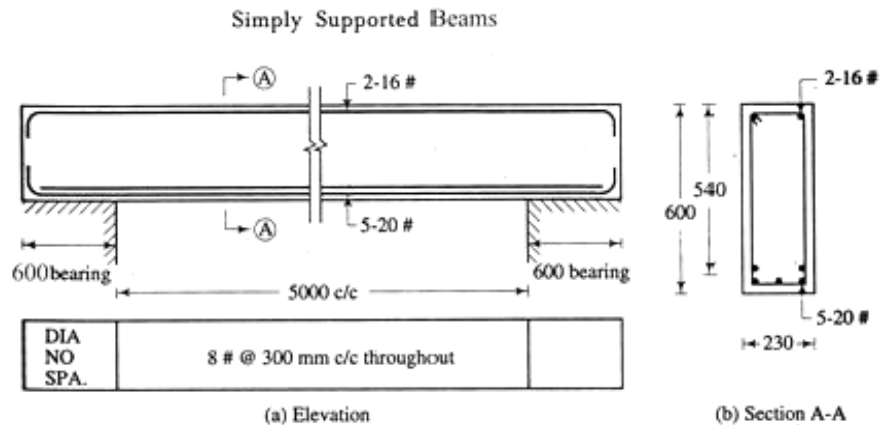

### 7.3:Design

#### of T beams as per IS 456 for bending and shear

#### DESIGN OF T BEAM

Case-1: To design the beam for a given loading condition

- (i) Fixe the width of the beam using architectural consideration. Also the width shall be sufficient to accommodate the reinforcement satisfying the requirement of spacing of bars
- (ii) Effective width of flange for T beam  $= b_f = \frac{S_0}{6} + b_w + 6D_f$
- (iii) Assume overall depth D equal to 1/12 th to 1/10 of the span and subtracting effective concrete cover from overall depth, find out the effective depth d
- (iv) Assume lever arm  $Z = d - D_f/2$
- (v) Find out the reinforcement  $A_{ct} = \frac{M_u}{0.87 \times f_y \times Z}$
- (vi) Provide the reinforcement as per requirement.
- (vii) Then find out  $\frac{b_f}{b_w}$  and  $\frac{D_f}{d}$  then from table 58 of S.P16 find out the value of  $M_{ulim.T}$ . And check whether under reinforced or over reinforcement assuming the position of neutral axis

If the moment of resistance is less than the applied moment, revise the section.

$$\text{When } D \leq \frac{3}{7} x_u$$

$$M_u = 0.36 f_{ck} b_u x_u (d - 0.42 x_u) + 0.446 f_{ck} (b_f - b_w) \times D_f (d - \frac{D_f}{2})$$

$$\text{When } D \geq \frac{3}{7} x_u$$

$$M_u = 0.36 f_{ck} b_u x_u (d - 0.42 x_u) + 0.446 f_{ck} (b_f - b_w) \times D_f (d - \frac{D_f}{2})$$

$$\text{Where } Y_f = 0.15 x_u + 0.65 D_f$$

## Design for Shear

7. Find the Maximum S.F
8. Find the factored S.F ( $V_u$ )
9. Find the nominal shear stress  $v_v = \frac{V_u}{bd}$
10. Obtain the design shear strength of concrete corresponding to percentage of tensile reinforcement provided for flexure from table 19, pg-73 IS 456.  
Design shear strength ( $v_c$ ) :- It is the capacity of concrete along with tensile reinforcement. To take the amount of shear force without providing any reinforcement for shear.
11. Find the excess shear force for which shear reinforcement is required to be provided i.e.  $V_{us}$ .  $V_{us} =$  Applied shear – shear force to be resisted by concrete without any shear reinforcement.  
 $V_{uc} = V_u - v_c bd$
12. To determine the quantity of shear reinforcement in terms of stirrup spacing as under.

(v) For vertical stirrups

$$(vi) V_{uc} = \frac{0.87 f_y A_{sv} \times d}{S_v}$$

$V_{us}$  = Excess S.F to be resisted

$A_{sv}$  = Area of shear reinforcement.

$S_v$  = Spacing of stirrups

$$S_v = \frac{0.87 f_y A_{sv}}{d} V_{us}$$

(vii) For inclined stirrups

$$V_{uc} = \frac{0.87 f_y A_{sv} \times d (\sin \alpha + \cos \alpha)}{S_v}$$

Or

$$S_v = \frac{0.87 f_y A_{sv} d (\sin \alpha + \cos \alpha)}{V_{uc}}$$

(viii) For Bent up bars

$$V_{uc} = 0.87 f_y A_{sv} \cdot \sin \alpha$$

IS 456 says the contribution of bent up bars towards shear resistance shall not exceed half of the shear resistance.

$\alpha$  = angle between bent up the inclined stirrups or bent up bar and total axis of member not less than  $45^\circ$

e Minimum shear reinforcement .

Spacing of shear stirrups should not exceed the following.

$$\frac{A_{sv}}{b S_v} \geq \frac{0.4}{0.87 f_y}$$



$$(i) S_v = \frac{0.87 f_y A_{cv}}{0.4 b}$$

(ii) 0.75 d ( d = Effective depth)

(iii) 300 mm c/c distance

Design a simply supported tee beam of span 7 m and spaced at 3 m centres. The thickness of slab is 100 mm and total characteristic load including self-weight of the beam is 30 kN/m. The overall size of the beam is 230 mm × 600 mm. The materials are M20 grade concrete and HYSD reinforcement of grade Fe 415.

**Solution:**

$$\text{Factored load} = 1.5 \times 30 = 45 \text{ kN/m}$$

$$\text{Factored moment } M_u = 45 \times \frac{7^2}{8} = 275.6 \text{ kNm}$$

$$\text{Factored shear } V_u = 45 \times \frac{7}{2} = 157.5 \text{ kN.}$$

(a) *Moment steel:*

Assuming 2 layers of 20 mm # bars

$$d = 600 - 30 - 20 - 10 = 540 \text{ mm.}$$

As a preliminary design assume lever arm

$$z = d - \frac{D_f}{2} = 540 - \frac{100}{2} = 490 \text{ mm.}$$

$$A_{st} = \frac{M_u}{0.87 f_y z} = \frac{275.6 \times 10^6}{0.87 \times 415 \times 490} = 1558 \text{ mm}^2.$$

$$\text{Provide } 5\text{-}20 \text{ mm \#} = 5 \times 314 = 1570 \text{ mm}^2.$$

The section is now checked for moment of resistance.

$$\begin{aligned} b_f &= \frac{l_0}{6} + b_w + 6 D_f > 3000 \\ &= \frac{7000}{6} + 230 + 6 \times 100 = 1996 \text{ mm.} \end{aligned}$$

Use

$$b_f = 1990 \text{ mm}$$

$$\begin{aligned} F_{tc} &= 0.36 f_{ck} b_f D_f \\ &= 0.36 \times 20 \times 1990 \times 100 \times 10^{-3} = 1432.8 \text{ kN} \end{aligned}$$

$$\begin{aligned} F_{ts} &= 0.87 f_y A_{st} \\ &= 0.87 \times 415 \times 1570 \times 10^{-3} = 566.8 \text{ kN} \end{aligned}$$

$$F_{tc} > F_{ts}$$

∴ Neutral axis lies in flange.

Equating the forces

$$\text{Total compression} = \text{total tension}$$

$$0.36 f_{ck} b_f x_u = 0.87 f_y A_{st}$$

$$0.36 \times 20 \times 1990 x_u = 0.87 \times 415 \times 1570$$

$$\therefore x_u = 39.56 \text{ mm}$$

$$x_{u,max} = 0.48 d = 0.48 \times 540 = 259.2 \text{ mm}$$

$$x_u < x_{u,max}$$

∴ Under-reinforced section.

$$\begin{aligned}
 M_u &= 0.87 f_y A_{st} (d - 0.42 x_u) \\
 &= 0.87 \times 415 \times 1570 \times (540 - 0.42 \times 39.56) \times 10^{-6} \\
 &= 296.7 \text{ kNm} > 275.6 \text{ kNm} \dots\dots\dots (\text{O.K.})
 \end{aligned}$$

Let 2 bars bent up at  $1.25 \times 600 = 750 \text{ mm}$  from the face of the support.

(b) Check for devel

At support,  $A_{st} = 3 \times 314 = 942 \text{ mm}^2$ .

$$\begin{aligned}
 0.36 f_{ck} b_f x_u &= 0.87 f_y A_{st} \\
 &= \dots\dots\dots 154 \\
 x_u &= 23.74 \text{ mm.}
 \end{aligned}$$

$$\begin{aligned}
 M_{u1} &= 0.87 f_y A_{st} (d - 0.42 x_u) \\
 &= 0.87 \times \dots\dots\dots \times 942 \times (540 - 0.42 \times 23.74) \times 10^{-6} \\
 &= 180.2 \text{ kNm}
 \end{aligned}$$

$$V_u = 157.5 \text{ kN.}$$

As the ends of reinforcement are confined with compressive reaction, we have

Assume  $L_0 = 12 \#$

$$1.3 \times \frac{180.2 \times 10^6}{157.5 \times 10^3} + 12 \# \geq 47 \#$$

$$= 20 \text{ mm} \dots\dots\dots (\text{Safe})$$

# provided

As shaft ends are confined by compressive reaction, shear at distance  $d$  will be

$\therefore V_u = 157.5 - 0.540 \times 45 = 133.2 \text{ kN}$

$$\frac{100 A_s}{b d} = \frac{100 \times 942}{230 \times 540} = 0.758$$

$$\tau_c = 0.562 \text{ N/mm}^2$$

$$\tau_v = \frac{133.2 \times 10^3}{230 \times 540} = 1.06 \text{ N/mm}^2 > \tau_c$$

$\therefore$  shear deal qfi \s rzeceaxer y.

2.20 P bara ssn rasi< e yheur nf

$$0.87 \times 415 \times 2 \times 314 \times \sin 45^\circ \times 10^{-3} = 160.32 \text{ kN.}$$

$$V_{us} = V_u - \tau_c b d$$

$$= \dots\dots\dots \text{K.S.C} - \text{o,ssi} \cdot \text{c;9} \cdot \text{sio} \cdot \text{io} \cdot \text{-} - \text{s} \ll \text{to} @$$

Brnt b< r> th are 6tl - 'dI.7 kN

Stirrups 9hcre sU9t - .1\7 kif.

Using 6 mm  $\phi$  M.S. two-legged stirrups,  $A_{sv} = 56 \text{ mm}^2$

Use 2-10 # as anchor bars. The designed section is shown in fig.

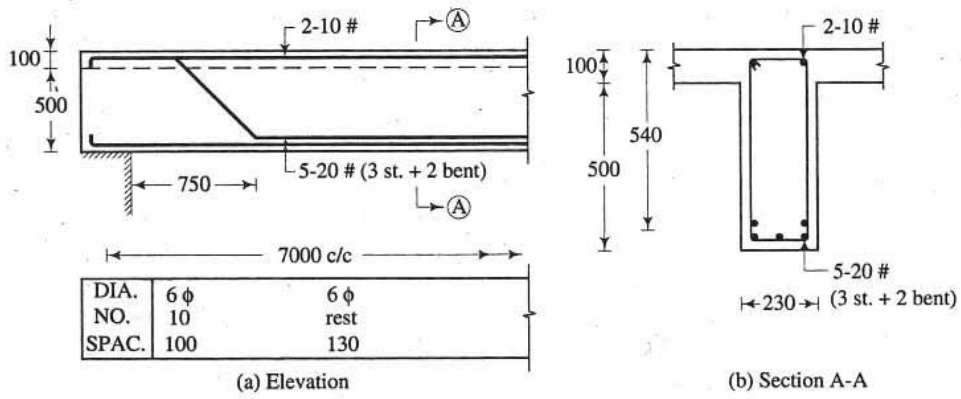

## CHAPTER 07

### ANALYSIS AND DESIGN OF SLABS AND STAIRCASE BY LIMIT STATE METHOD SLABS

- 8.1 : One way slab & two way slab
- 8.2 : One way & cantilever slabs as per IS-456 for bending & shear.
- 8.3: Explain the action of two way slabs with deflected shape.
- 8.4 : Provision for two way slab as per IS-456-2000
- 8.4.1: Middle strip & edge strip
- 8.4.2 : B.M Co-Efficient
- 8.4.3 : Torsion reinforcement
- 8.4.4 : Design of two way slab as per IS-456-2000 & SF-16 hand hook
- 8.4.5 : Check for **deflection**, development length & reinforcement. Requirement & spacing as per Sp-16 & IS-456

Slabs: Slabs are plate elements & carry loads primarily by flexure. They usually carry Vertical loads

#### Classification of Slab:

1. One way spanning slab
2. Two-way spanning slab
3. Flat slab
4. Grid slab
5. Circular and other shapes
6. Ribbed slab

One way spanning slab: The slab supported on two opposite supports is a one way spanning slab.

On the other way a slab which transfer its load on one of the set of two opposite edge supports is called one-way slab. In this case  $l_y/l_x$  is greater than two.

Two way spanning Slab: The Slab which is supported on all four edges and if  $l_y \leq 2l_x$  slabs bend in both directions. Such slabs are called two way spanning slab.

$$\frac{l_y}{l_x} < 2$$

8.2 One way & cantilever slabs as per IS: 456 for bending & shear.

One way spanning slab

1. Effective Span = Clear Span + Effective depth

or

Centre to centre of Support whichever is less

Moment Steel: The reinforcement in the direction of span is known as moment steel. The moment steel is known as main reinforcement.

**Distribution Steel:** The reinforcement perpendicular to the main reinforcement. Is known as distribution steel & placed in second layer. This reinforcement resists temp & shrinkage stresses, keeps the main reinforcement in position and distributes the concentrated or non uniform loads throughout the slab.

For a continuous slab at support, top reinforcement is provided as main steel to resist negative B.M.

$$\text{Spacing of slab bar} = \frac{\text{area of one bar} \times 1000}{\text{required area in } \text{mm}^2 \text{ per Meter}}$$

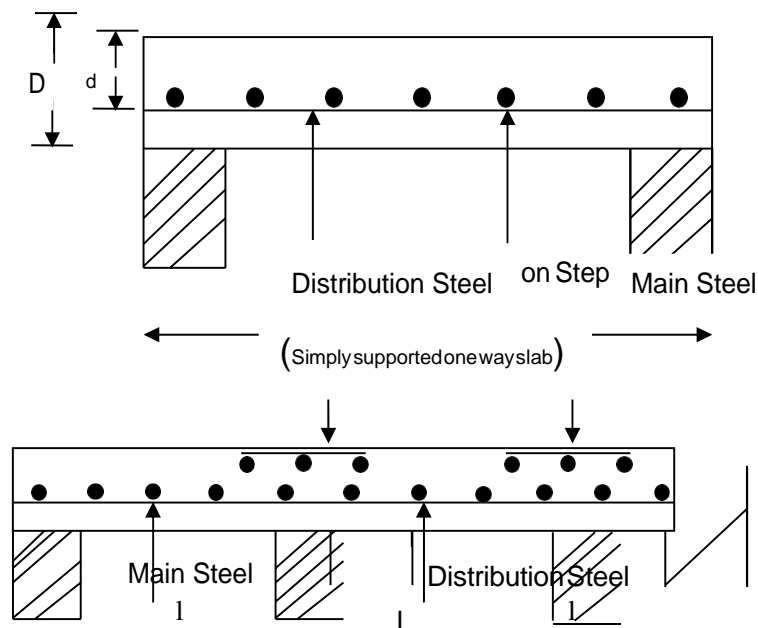

## 2. Reinforcement requirement

- (i) **Minimum reinforcement:-** The reinforcement in either direction in slabs shall not be less than 0.15% of the total c/s area. For HYSD bars, it shall not be less than 0.12%. thus in slabs, minimum reinforcement less than 0.85/f<sub>y</sub> is permissible .
- (ii) **Maximum diameter:** The diameter of reinforcing bar shall not exceed 1/8<sup>th</sup> the total thickness of slab.
- (iii) **Minimum diameter:** For main bars, minimum diameter shall be 10mm for plain bars & 8 mm for deformed bar for distribution bars, the minimum diameter shall be 6mm

**Shear Stress:**

$$\text{Design shear strength} = K v_c c_{\max}$$

$$\text{Nominal shear stress} \leq 0.5 v_c c_{\max}$$

This shall be checked

**Deflection:** It shall be checked as per beam

## Cracking:

- (i) The horizontal distance between parallel main reinforcement, shall not be more than 3 times the effective depth of a solid slab or 300mm whichever is smaller.
- (ii) The horizontal distance between parallel reinforcement bars against shrinkage & temperature shall not be more than 5 times the effective depth of a solid slab or 450 mm whichever is smaller.

Cover: For mild exposure, clear over = 20mm

When  $\phi \leq 10$  mm clear cover = 15mm

$\phi > 12$ mm, clear cover = 20mm

## Development Length:

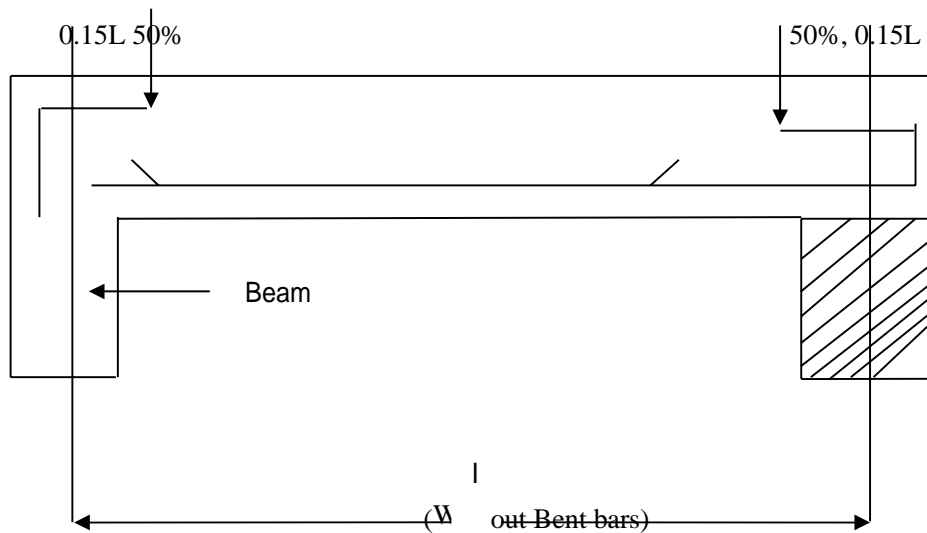

(Typical details of simply supports slab)

The bars can be bent up or curtailed only if continuing bars provide minimum reinforcement. & check for development length is satisfied.

### Example

A simply supported one-way slab of clear span 3.0 m is supported on masonry walls of thickness 350 mm. Slab is used for residential loads. Design the slab. The materials are grade M 20 concrete and HYSD reinforcement of grade Fe 415. Live load shall be 2 kN/m<sup>2</sup>.

### Solution:

*Depth of slab:* The first trial of depth of slab can be arrived at by considering deflection criterion. Assuming percentage of steel reinforcement, find out modification factor as explained in art. 8-1. Percentage of steel depends on the loading on slab. A designer, after some practice will be able to find out his own thumb rules for the trial depth.

Assume 0.30 per cent steel as a first trial with service stress of  $0.58 f_y = 0.58 \times 415 = 240 \text{ N/mm}^2$ . Basic  $\frac{\text{span}}{d}$  ratio = 20. Also modification factor from fig. 8-1 is 1.45.

Then permissible  $\frac{\text{span}}{d}$  ratio =  $20 \times 1.45 = 29$ . The depth  $d = \frac{3100}{29} = 106.9 \text{ mm}$ . Considering mild exposure and maximum diameter of reinforcement be 12 mm, clear cover = 15 mm. Therefore  $D = 106.9 + 6 + 15 = 127.9 \text{ mm}$ .

Assume 130 mm overall depth of slab.

$$DL = 0.13 \times 25 = 3.25 \text{ kN/m}^2$$

$$\text{Floor finish} = 1.00 \text{ kN/m}^2$$

$$\text{Live load} = \underline{2.00 \text{ kN/m}^2}$$

$$\text{Total} \quad 6.25 \text{ kN/m}^2$$

$$\text{Factored load} = 1.5 \times 6.25 = 9.4 \text{ kN/m}^2.$$

Effective span (1)  $3000 + 350 = 3350 \text{ mm c/c supports}$

(2)  $3000 + 110 \text{ (effective depth)} = 3110 \text{ mm}$ .

Use 3.11 m effective span.

*Moment and shear:*

Consider 1 m length of slab

$\therefore$  load = 9.4 kN/m.

$$\text{Maximum moment} = 9.4 \times \frac{3.11^2}{8} = 11.36 \text{ kNm.}$$

$$\text{Maximum shear} = 9.4 \times \frac{3}{2} = 14.1 \text{ kN (based on clear span).}$$



Effective depth required for flexure  $L_x$

$$= \sqrt{\frac{11.36 \times 10^6}{1000 \times 2.76}} = 64.15 \text{ mm.}$$

( $Q = 2.76$  for M 20 mix and Fe 415 steel)

$$d_{\text{provided}} = 130 - 15 \text{ (cover)} - 5 \text{ (assume 10 } \phi \text{ bar)}$$

$$= 110 \text{ mm} \dots \dots \dots \text{ (O.K.)}$$

Design for flexure:

$$\frac{M_u}{b d^2} = \frac{11.36 \times 10^6}{1000 \times 110^2} = 0.939$$

$$p_t = \frac{100 A_{st}}{b d} = 0.281$$

$$\therefore A_{st} = \frac{0.281 \times 1000 \times 110}{100} = 309 \text{ mm}^2.$$

Provide 8 mm # about 150 mm c/c = 335 mm<sup>2</sup>.

Note that use of design tables give correct answer for steel required.

Half the bars are bent at  $0.1 l = 0.1 \times 3100 = 310$  mm.

Remaining bars provide 167.5 mm<sup>2</sup> area.

$$\frac{100 A_s}{b D} = \frac{100 \times 167.5}{1000 \times 130} = 0.129 > 0.12$$

i.e., remaining bars provide minimum steel. Thus half the bars may be bent up

Distribution steel =  $\frac{0.15}{100} \times 1000 \times 130 = 195$  mm<sup>2</sup>, using mild steel.

Maximum spacing  $5 \times 100 = 500$  or 450 mm, i.e., 450 mm.

Provide 6 mm  $\phi$  about 140 mm c/c = 202 mm<sup>2</sup>.

Check for shear:

For bars at support

$$\text{correct } d = 130 - 15 - 4$$

$$= 111 \text{ mm}$$

$$\frac{100 A_s}{b D} = \frac{100 \times 167.5}{1000 \times 111} = 0.15.$$

For slab upto 150 mm thickness,  $k = 1.3$

$\tau_c$  from table 7-1 = 0.28 N/mm<sup>2</sup>.

Design shear strength

$$= k \tau_c = 1.3 \times 0.28$$

$$= 0.364 \text{ N/mm}^2.$$

$$\text{Actual shear stress} = \frac{13.5 \times 10^3}{1000 \times 111} = 0.122 \text{ N/mm}^2 < 0.364 \text{ N/mm}^2 \dots \dots \text{ (safe)}$$

Check for development length:

Refer to fig. 10-5.

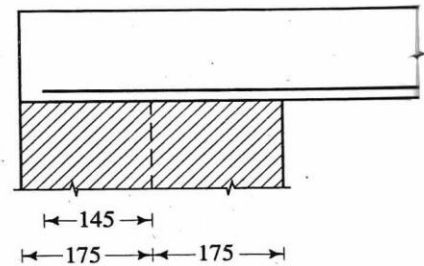

Details at support for bottom bars  
FIG. 10-5

$L_0 = 145$  mm.  $L_0$  is limited to  $12 \phi = 96$  mm or  
 $d = 100$  mm, whichever is greater.

$L_0 = 100$  mm.

For continuing bars,  $A_s = 167.5$  mm<sup>2</sup>. Also, the ends of the reinforcement are confined by compressive reaction.

$$M_{u1} = 0.87 f_y A_{st} d \left( 1 - \frac{f_y A_{st}}{b d f_{ck}} \right)$$

$$M_{u1} = 0.87 \times 415 \times 167.5 \times 111 \left( 1 - \frac{415 \times 167.5}{1000 \times 111 \times 20} \right) \times 10^{-6}$$

$$= 6.5 \text{ kNm.}$$

$$V_u = 13.5 \text{ kN.}$$

$$1.3 \frac{M_{u1}}{V_u} + L_0 \geq L_d \quad \text{where } L_d = 47 \#$$

$$1.3 \times \frac{6.5 \times 10^6}{13.5 \times 10^3} + 100 \geq 47 \#$$

or  $15.4 \text{ mm} \geq \# \dots\dots\dots (\text{O.K.})$

Check for deflection :

$$\text{Basic } \frac{\text{span}}{d} \text{ ratio} = 20$$

$$p_t = \frac{100 \times 335}{1000 \times 111} = 0.3$$

$$\text{service stress} = 0.58 \times 415 \times \frac{303}{335} = 218 \text{ N/mm}^2.$$

$$\text{modification factor} = 1.62$$

$$\text{permissible } \frac{\text{span}}{d} \text{ ratio} = 20 \times 1.62 = 32.4$$

$$\text{actual } \frac{\text{span}}{d} \text{ ratio} = \frac{3100}{111}$$

$$= 28 < 32.4 \dots\dots\dots (\text{O.K.})$$

Note: The depth could be slightly reduced. Try with  $D = 125$  mm from beginning and rework the problem

Check for cracking:

Maximum spacing permitted for main reinforcement

$$= 3 \times 100 = 300 \text{ mm.}$$

Actual spacing = 150 mm < 300 mm  $\dots\dots\dots (\text{O.K.})$

For distribution steel, maximum spacing permitted

$$= 5 \times 100$$

$$= 500 \text{ or } 450 \text{ mm, i.e., } 450 \text{ mm.}$$

Spacing provided = 150 m  $\dots\dots\dots (\text{O.K.})$

For tying the bent bars at top, 6 mm  $\phi$  about 150 mm c/c distribution steel shall be provided.

*Sketch: The cross-section of the slab*

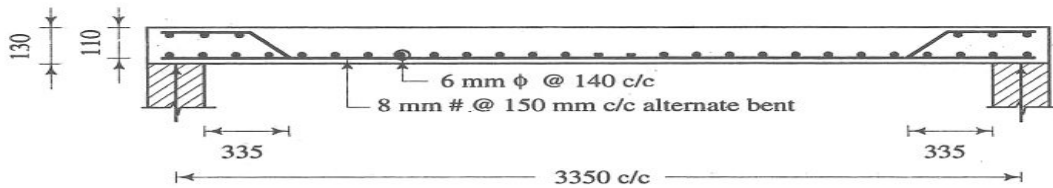

Design the slab S2 – S1 of above figure , if it is to be used for residential purpose at the free end of slab S1 there is a concrete parapet of 75mm thick and 1 m high. The materials are M20 grade concrete and HYSD reinforcement of grade Fe 415 . Use IS:875 for live loads.

**Solution**

Estimation of loads:

For slab S2 live load shall be 2 kN/m<sup>2</sup>. For slab s1 which is a balcony slab live load shall be 3 kN/m<sup>2</sup>. Assume 120 mm thick slab.

Slab S <sub>2</sub> :	Self load = 0.12 × 25	= 3 + 0 kN/m <sup>2</sup>
	Floor finish	= 1 + 0 kN/m <sup>2</sup>
	Live load	= 0 + 2 kN/m <sup>2</sup>
	<b>Total</b>	<b>= 4 + 2 kN/m<sup>2</sup></b>
	<b>P<sub>u</sub></b>	<b>= 1.5(4+2)</b>
		<b>= (6+3) kN/m<sup>2</sup></b>

Slab <sub>1</sub> :	Self load	= 3 + 0 kN/m <sup>2</sup>
	Floor finish	= 1 + 0 kN/m <sup>2</sup>
	Live load	<b>= 0 + 3 kN/m<sup>2</sup></b>
	<b>Total</b>	<b>= 4 + 3 kN/m<sup>2</sup></b>
	<b>P<sub>u</sub></b>	<b>= 1.5(4+3)</b>
		<b>= 6+4.5 kN/m<sup>2</sup></b>

Weight of parapet

$$0.075 \times 25 \times 1 = 1.875 \text{ kN/m.}$$

$$p_u = 1.5 \times 1.875 = 2.8 \text{ kN/m.}$$

Analysis :

Consider 1m long strip.

1 To get maximum positive moment in slab s2 only dead load on slab s1 and total load on slab s2 shall be considered. The parapet load is a dead load but will not be considered as sometimes the owner of the building or architect may change his mind and would provide simply a railing.

Considering above figure

$$\text{Cantilever moment} = \frac{1.2^2}{2} \times 6 = 4.32 \text{ kNm.}$$

$$\text{Reaction at A} = \frac{9 \times 3}{2} - \frac{4.32}{3} = 12.06 \text{ kN}$$

$$\text{Point of zero shear from A} = \frac{12.06}{9} = 1.34 \text{ m.}$$

$$\begin{aligned} \text{Maximum positive moment} &= 12.06 \times 1.34 - \frac{1.34^2}{2} \times 9 \\ &= 16.16 - 8.08 \text{ kNm.} \end{aligned}$$

To check shear and development length at A, shear may be considered as 12.06 kN. Note that for the cantilever, clear span is considered

2 To get maximum negative moment and maximum shear at B , the slab is loaded with full loads

$$\begin{aligned} \text{Maximum negative moment} &= 1.2 \frac{1.2^2}{2} \times 10.5 + 1.2 \times 2.8 \\ &= 7.56 + 3.36 = 10.92 \text{ kNm.} \end{aligned}$$

$$\text{Maximum shear at B, } V_u, BA = \frac{9 \times 3}{2} + \frac{10.92}{3} = 13.5 + 3.64 = 17.14 \text{ kN}$$

$$V_u, BC = 10.15 \times 1.2 + 2.8 = 15.4 \text{ kN.}$$

C) Moment steel:

Maximum moment = 10.92 kN.

$$d_{\text{required}} = \sqrt{\frac{10.92 \times 10^6}{1000 \times 2.76}} = 62.9 \text{ mm}$$

$$d_{\text{provided}} = 120 - 15 - 5 \text{ (assume 10\# bar)}$$

$$= 100 \text{ mm} \dots \dots \dots \text{ (O.K)}$$

$$\frac{M_u}{bd^2} (+) = \frac{8.08 \times 10^6}{1000 \times 100 \times 100} = 0.81$$

$$P_t = 0.236$$

$$A_{st} (+) = \frac{0.236 \times 1000 \times 100}{100} = 2.36 \text{ NN}^2$$

$$\frac{M_u}{bd^2} (-) = \frac{10.92 \times 10^6}{1000 \times 100 \times 100} = 1.09$$

$$P_t = 0.324$$

$$A_{st} (-) = \frac{0.324 \times 1000 \times 100}{100} = 324 \text{ NN}^2$$

For positive moment provide 8 mm # about 170 mm c/c giving 294 mm<sup>2</sup> alternate bent up and for negative moment provide 8 mm # about 340 mm c/c (bent bar extended) + 10 mm # 340 mm c/c giving 378 mm<sup>2</sup> area . The arrangement of reinforcement is shown in the below figure.

Note that at simple support, the bars are bent at 0.1 L whereas at continuity of slab it is bent at 0.2 L.

$$\text{Minimum steel} = \frac{0.12}{100} \times 1000 \times 120 = 144 \text{ NN}^2 .$$

Remaining positive moment bars give  $A_s = \frac{294}{2} = 147 \text{ mm}^2$  Thus bar can be bent up.

$$\text{Distribution steel} = \frac{0.15}{100} \times 1000 \times 120 = 180 \text{ NN}^2 .$$

Provide 6 mm # about 150 mm c/c = 187 mm<sup>2</sup> .

For negative moment reinforcement

$$L_d = 47 \#$$

$$L_d = 47 \times \frac{(8+10)}{2} = 423 \text{ mm}.$$

The bars must be anchored upto 423 mm. also they should be extended upto 12 # beyond the point of contraflexure, which may be found out . Alternatively as a thumb rule, a bar shall be given an anchorage equal to the length of the cantilever. Adopting this, carry the top bars upto 1200 mm in the internal span. This is shown in above figure.

d) Check for Development length :

$$\begin{aligned} \text{At A, } M_{ul} &= 0.87 f_y A_{ct} \left( d - \frac{f_y E_{ct}}{b f_{ck}} \right) \\ &= 0.87 \times 415 \times 147 \left( 100 - \frac{415 \times 417}{1000 \times 20} \right) \times 10^{-6} \\ &= 5.15 \text{ kNm.} \\ V_u &= 12.06 \text{ kN.} \end{aligned}$$

Consider  $L_0 = 8 \#$

Then  $1.3 \frac{M_{ul}}{V_u} + L_0 \geq L_d$

$$1.3 \times \frac{5.15 \times 10^6}{12.06 \times 10^3} + 8 \# \geq 47 \#$$

At B,  $M_{ul} = 5.15 \text{ kNm}$ .

Near point of contraflexure, i.e.  $0.15 L$  from B

$$V_u = 17.14 - 0.45 \times 9 = 13.09 \text{ kN}$$

$$1.3 \times (5.15 \times 10^6 / 13.09 \times 10^3) + 8 \# \geq 47 \#$$

$$\# \leq 13.11 \text{ mm}$$

Check for Shear

Span AB: At A,  $V_{u,AB} = 12.06 \text{ KN}$

At B, shear at point of contraflexure =  $13.09 \text{ kN}$

Hence  $V_u = 13.09 \text{ KN}$

$$\text{Shear stress } \tau_v = 13.09 \times 10^3 / 1000 \times 100 = 0.131 \text{ N/mm}^2$$

$$\frac{100 A_{E_c}}{bd} = 100 \times 147 / 1000 \times 100 = 0.147$$

$$\tau_c = 0.28$$

$$k \times \tau_c = 0.28 \times 1.3 = 0.364 \text{ N/mm}^2 > \tau_v$$

Span BC

$$\therefore V_u = 17.14 \text{ KN}$$

$$\text{Shear stress } \tau_v = 17.14 \times 10^3 / 1000 \times 100 = 0.171 \text{ N/mm}^2$$

$$\frac{100 A_{E_c}}{bd} = 100 \times 378 / 1000 \times 100 = 0.378$$

$$\tau_c = 0.28$$

$$k \times \tau_c = 0.421 \times 1.3 = 0.547 \text{ N/mm}^2 > \tau_v$$

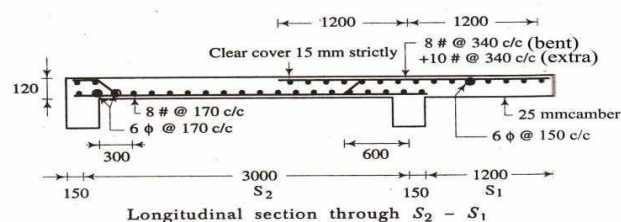

Two way Slabs:

The two way spanning slab

Occurs when the slab is supported

On all four edges

When  $\frac{L_y}{L_x} < 2$ , it is called two way slab.

Design

$$M_x = \alpha_x \cdot w \cdot L_x^2$$

$$M_y = \alpha_y \cdot w \cdot l_y^2$$

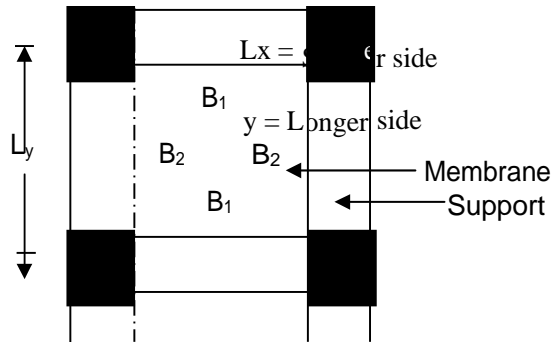

$M_x, M_y$  = Moments on strips of unit width

spanning  $L_x$  &  $L_y$  respectively.

$\alpha_x, \alpha_y$  = Co-efficient

$L_x, L_y$  = Lengths of shorter span & Longer span

Respectively

$W$  = Total design load per unit area. IS -456 also states that at least 50% of the tension reinforcement. Provided at mid span intend to within 0.1  $L_x$  or 0.1  $L_y$  of the support.

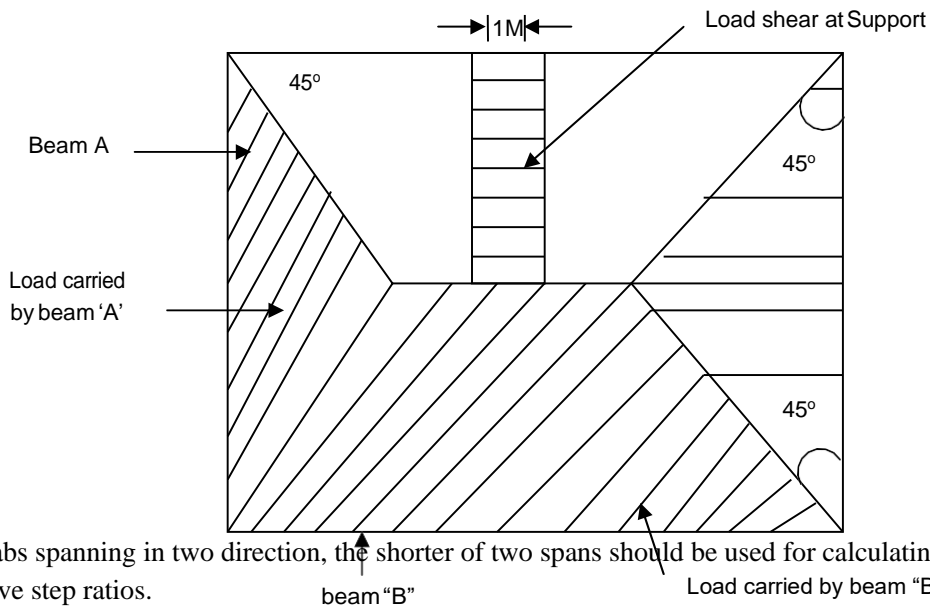

For slabs spanning in two direction, the shorter of two spans should be used for calculating the span to effective step ratios.

For two way slabs for span up to 3.5 with mild steel reinforcement.  $\frac{span}{d} = 35$  for simply supported slabs

$\frac{span}{d} = 40$  for continuous slab for HYSD of grade Fe 415, there values are multiplied by 0.8.

Provison two way slab as per IS 456:2000

### Middle Strip and edge strip

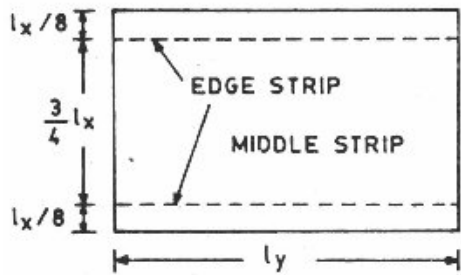

Middle and edge strips along the long span

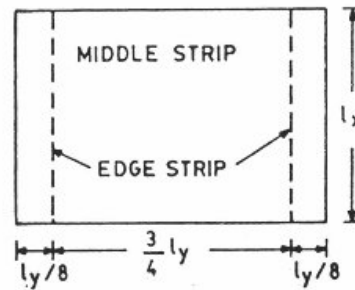

Middle and edge strips along the short span

### Bending moment Coefficients with torsion reinforcement

Table 8.6 Maximum bending moments of Problem 8.2 For	Short span			Long span
	$\alpha_x$	$M_x$ (kNm/m)	$\alpha_y$	$M_y$ (kNm/m)
Negative moment at continuous edge	0.075	18.6	0.047	11.66
Positive moment at mid-span	0.056	13.89	0.035	8.68



**Table 26 Bending Moment Coefficients for Rectangular Panels Supported on Four Sides with Provision for Torsion at Corners**  
(Clauses D-1.1 and 24.4.1)

Case No.	Type of Panel and Moments Considered	Short Span Coefficients $\alpha_x$ (Values of $l_y/l_x$ )								Long Span Coefficients $\alpha_y$ for All Values of
		1.0 (3)	1.1 (4)	1.2 (5)	1.3 (6)	1.4 (7)	1.5 (8)	1.75 (9)	2.0 (10)	$l_y/l_x$ (11)
1	<i>Interior Panels:</i> Negative moment at continuous edge Positive moment at mid-span	0.032 0.024	0.037 0.028	0.043 0.032	0.047 0.036	0.051 0.039	0.053 0.041	0.060 0.045	0.065 0.049	0.032 0.024
2	<i>One Short Edge Continuous:</i> Negative moment at continuous edge Positive moment at mid-span	0.037 0.028	0.043 0.032	0.048 0.036	0.051 0.039	0.055 0.041	0.057 0.044	0.064 0.048	0.068 0.052	0.037 0.028
3	<i>One Long Edge Discontinuous:</i> Negative moment at continuous edge Positive moment at mid-span	0.037 0.028	0.044 0.033	0.052 0.039	0.057 0.044	0.063 0.047	0.067 0.051	0.077 0.059	0.085 0.065	0.037 0.028
4	<i>Two Adjacent Edges Discontinuous:</i> Negative moment at continuous edge Positive moment at mid-span	0.047 0.035	0.053 0.040	0.060 0.045	0.065 0.049	0.071 0.053	0.075 0.056	0.084 0.063	0.091 0.069	0.047 0.035
5	<i>Two Short Edges Discontinuous:</i> Negative moment at continuous edge Positive moment at mid-span	0.045 0.035	0.049 0.037	0.052 0.040	0.056 0.043	0.059 0.044	0.060 0.045	0.065 0.049	0.069 0.052	— 0.035
6	<i>Two Long Edges Discontinuous:</i> Negative moment at continuous edge Positive moment at mid-span	— 0.035	— 0.043	— 0.051	— 0.057	— 0.063	— 0.068	— 0.080	— 0.088	0.045 0.035
7	<i>Three Edges Discontinuous (One Long Edge Continuous):</i> Negative moment at continuous edge Positive moment at mid-span	0.057 0.043	0.064 0.048	0.071 0.053	0.076 0.057	0.080 0.060	0.084 0.064	0.091 0.069	0.097 0.073	— 0.043
8	<i>Three Edges Discontinuous (One Short Edge Continuous):</i> Negative moment at continuous edge Positive moment at mid-span	— 0.043	— 0.051	— 0.059	— 0.065	— 0.071	— 0.076	— 0.087	— 0.096	0.057 0.043
9	<i>Four Edges Discontinuous:</i> Positive moment at mid-span	0.056	0.064	0.072	0.079	0.085	0.089	0.100	0.107	0.056

moments per unit width are given by the following equation:

$$M_x = \alpha_x w l_x^2$$

$$M_y = \alpha_y w l_y^2$$

where  $M_x, M_y, w, l_x, l_y$  are same as those in D-1.1.

and  $\alpha_x$  and  $\alpha_y$  are moment coefficients given in Table 27

**D-2.1.1** At least 50 percent of the tension reinforcement provided at mid-span should extend to the supports. The remaining 50 percent should extend to within 0.1  $l_x$  or 0.1  $l_y$  of the support, as appropriate.

**Table 27 Bending Moment Coefficients for Slabs Spanning in Two Directions at Right Angles, Simply Supported on Four Sides**  
(Clause D-2.1)

$l_y/l_x$	1.0	1.1	1.2	1.3	1.4	1.5	1.75	2.0	2.5	3.0
$\alpha_x$	0.062	0.074	0.084	0.093	0.099	0.104	0.113	0.118	0.122	0.124
$\alpha_y$	0.062	0.061	0.059	0.055	0.051	0.046	0.037	0.029	0.020	0.014

Problem 1:

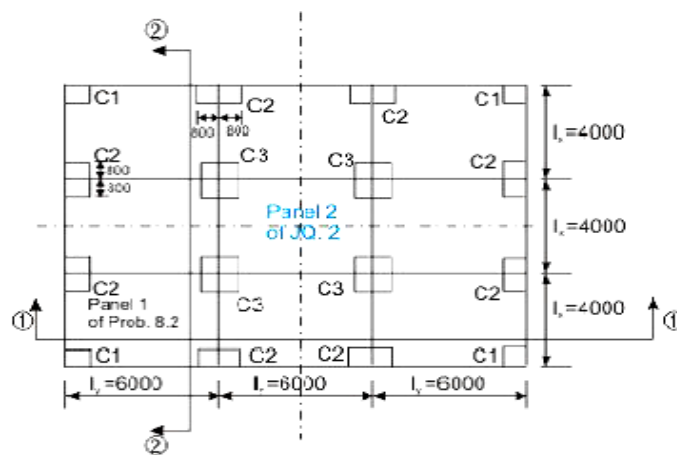

**Fig. 8.19.7: Problem 8.2 (panel 1) and TQ 2 (panel 2)**

### Step 1: Selection of preliminary depth of slab

The span to depth ratio with Fe 415 is taken from cl. 24.1, Note 2 of IS 456 as  $0.8(35 + 40) / 2 = 30$ . This gives the minimum effective depth  $d = 4000/30 = 133.33$  mm, say 135 mm. The total depth  $D$  is thus 160 mm.

### Step 2: Design loads, bending moments and shear forces

Dead load of slab (1 m width) =  $0.16(25) = 4.0$  kN/m<sup>2</sup>

Dead load of floor finish (given) =  $1.0$  kN/m<sup>2</sup>

Factored dead load =  $1.5(5) = 7.5$  kN/m<sup>2</sup>

Factored live load (given) =  $8.0$  kN/m<sup>2</sup>

Total factored load =  $15.5$  kN/m<sup>2</sup>

The coefficients of bending moments and the bending moments  $M_x$  and  $M_y$  per unit width (positive and negative) are determined as per cl. D-1.1 and Table 26 of IS 456 for the case 4, "Two adjacent edges discontinuous" and presented in Table 8.6. The  $l_y/l_x$  for this problem is  $6/4 = 1.5$ .

Table 8.6 Maximum bending moments of Problem 8.2

For	Short span			Long span
	$\alpha_x$	$M_x$ (kNm/m)	$\alpha_y$	$M_y$ (kNm/m)
Negative moment at continuous edge	0.075	18.6	0.047	11.66
Positive moment at mid-span	0.056	13.89	0.035	8.68

Maximum shear force in either direction is determined from Eq.8.1 (Fig.8.19.1) as

$$V_u = w_u(l/2) = 15.5(4/2) = 31 \text{ kN/m}$$

### Step 3: Determination/checking of the effective depth and total depth of slab

Using the higher value of the maximum bending moments in  $x$  and  $y$  directions from Table 8.6, we get from Eq.3.25 of Lesson 5 (sec. 3.5.5):

$$M_{u,lim} = Q_{lim} b d^2$$

$$\text{or } d = [(18.6)(10^6) / \{2.76(10^3)\}]^{1/2} = 82.09 \text{ mm,}$$

where  $2.76$  N/mm<sup>2</sup> is the value of  $Q_{lim}$ . Since, this effective depth is less than 135 mm assumed in Step 1, we retain  $d = 135$  mm and  $D = 160$  mm.

### Step 4: Depth of slab for shear force

Table 19 of IS 456 gives the value of  $\tau_c = 0.28$  N/mm<sup>2</sup> when the lowest percentage of steel is provided in the slab. However, this value needs to be modified by multiplying with  $k$  of cl. 40.2.1.1 of IS 456. The value of  $k$  for the total depth of slab as 160 mm is 1.28. So, the value of  $\tau_c$  is  $1.28(0.28) = 0.3584$  N/mm<sup>2</sup>.

Table 20 of IS 456 gives  $\tau_{cmax} = 2.8$  N/mm<sup>2</sup>. The computed shear stress  $\tau_v = V_u / b d = 31/135 = 0.229$  N/mm<sup>2</sup>.

Since,  $\tau_v < \tau_c < \tau_{max}$ , the effective depth of the slab as 135 mm and the total depth as 160 mm are safe.

**Step 5: Determination of areas of steel**

The respective areas of steel in middle and edge strips are to be determined. It has been shown that the areas of steel computed from Eq.3.23 and those obtained from the tables of SP-16 are in good agreement. Accordingly, the areas of steel for this problem are computed from the respective Tables 40 and 41 of SP-16 and presented in Table 8.7. Table 40 of SP-16 is for the effective depth of 150 mm, while Table 41 of SP-16 is for the effective depth of 175 mm. The following results are, therefore, interpolated values obtained from the two tables of SP-16.

Table 8.7 Reinforcing bars of Problem 8.2

Particulars	Short span $l_x$				Long span $l_y$	
	Table No.	$M_x$ (kNm/m)	Dia. & spacing	Table No.	$M_y$ (kNm/m)	Dia. & spacing
Top steel for negative moment	40,41	18.68 > 18.6	10 mm @ 200 mm c/c	40,41	12.314 > 11.66	8 mm @ 200 mm c/c
Bottom steel for positive moment	40,41	14.388 > 13.89	8 mm @ 170 mm c/c	40,41	9.20 > 8.68	8 mm @ 250 mm c/c

The minimum steel is determined from the stipulation of cl. 26.5.2.1 of IS 456 and is

$A_s = (0.12/100)(1000)(160) = 192 \text{ mm}^2$  and 8 mm bars @ 250 mm c/c (= 201 mm<sup>2</sup>) is acceptable. It is worth mentioning that the areas of steel as shown in Table 8.7 are more than the minimum amount of steel.

**Step 6: Selection of diameters and spacing of reinforcing bars**

The advantages of using the tables of SP-16 are that the obtained values satisfy the requirements of diameters of bars and spacing. However, they are checked as ready reference here. Needless to mention that this steel may be omitted in such a situation.

Maximum diameter allowed, as given in cl. 26.5.2.2 of IS 456, is  $160/8 = 20 \text{ mm}$ , which is more than the diameters used here.

The maximum spacing of main bars, as given in cl. 26.3.3(1) of IS 456, is the lesser of  $3(135)$  and 300 mm. This is also satisfied for all the bars.

**Step 7: Determination of torsional reinforcement**

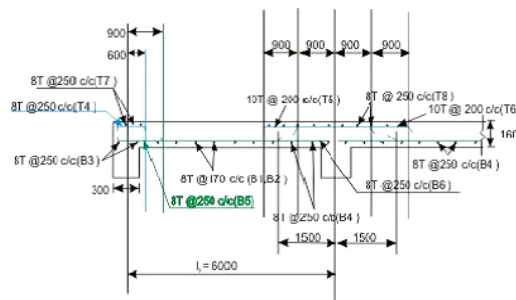

Fig. 8.19.8: Problem 8.2, Sec 1-1 of Panel 1 of Fig. 8.19.7

Torsional reinforcing bars are determined for the three different types of corners as explained in sec. 8.19.6 (Fig.8.19.4). The length of torsional strip is  $4000/5 = 800$  mm and the bars are to be provided in four layers. Each layer will have 0.75 times the steel used for the maximum positive moment. The C1 type of corners will have the full amount of torsional steel while C2 type of corners will have half of the amount provided in C1 type. The C3 type of corners do not need any torsional steel. The results are presented in Table 8.8 and Figs.8.19.10 a, b and c.

Table 8.8 Torsional reinforcement bars of Problem 8.2

Type	Dimensions along		Bar diameter & spacing	No. of bars along	Cl. no. of IS 456	
	x (mm)	y (mm)			x	y
C1	800	800	8 mm @ 200 mm c/c	5	5	D-1.8
C2	800	1600	8 mm @ 250 mm c/c	5	8	D-1.9
C2	1600	800	8 mm @ 250 mm c/c	8	5	D-1.9

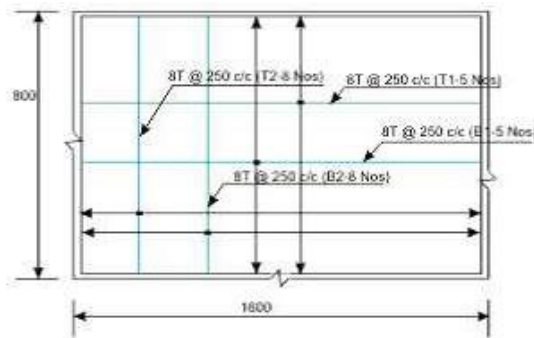

Fig. 8.19.10(c): Corners C2

Fig. 8.19.10: Torsion reinforcement bars of Problem 8.2

### Problem No 2

A drawing room of a residential building measures 4.3 m × 6.55 m. It is supported on 350 mm thick walls on all four sides. The slab is simply supported at edges with no provision to resist torsion at corners. Design the slab using grade M 20 concrete and HYSD reinforcement of grade Fe 415.

#### Solution:

Consider 1 m wide strip. Assume 180 mm thick slab, with 160 mm effective depth.

$$l_x = 4.3 + 0.16 = 4.46 \text{ say } 4.5 \text{ m.}$$

$$l_y = 6.55 + 0.16 = 6.71 \text{ say } 6.75 \text{ m.}$$

$$\text{Dead load: self } 0.18 \times 25 = 4.5 \text{ kN/m}^2$$

$$\text{floor finish} = 1.0 \text{ kN/m}^2$$

$$\text{Live load (residence)} = 2.0 \text{ kN/m}^2$$

$$\text{Total } 7.5 \text{ kN/m}^2$$

For 1 m wide strip

$$P_u = 1.5 \times 7.5 = 11.25 \text{ kN/m.}$$

$$\frac{l_y}{l_x} = \frac{6.75}{4.5} = 1.5$$

$$M_{ux} = 0.104 \times 11.25 \times 4.5^2 = 23.7 \text{ kNm}$$

$$M_{uy} = 0.046 \times 11.25 \times 4.5^2 = 10.48 \text{ kNm}$$

$$d_{\text{required}} = \sqrt{\frac{23.7 \times 10^6}{1000 \times 2.76}} = 92.7 \text{ mm}$$

$$d_{\text{short}} = 180 - 15 \text{ (cover)} - 5$$

$$= 160 \text{ mm} > 92.7 \text{ mm} \dots\dots\dots (\text{O.K.})$$

$$d_{\text{long}} = 160 - 10 = 150 \text{ mm}$$

Larger depth is provided to satisfy deflection check.

$$\frac{M_u}{bd^2} \text{ (short)} = \frac{23.7 \times 10^6}{1000 \times 160 \times 160} = 0.926$$

$$p_t = 0.273$$

$$A_{st} \text{ (short)} = \frac{0.273 \times 1000 \times 160}{100} = 437 \text{ mm}^2.$$

$$\frac{M_u}{bd^2} \text{ (long)} = \frac{10.48 \times 10^6}{1000 \times 150 \times 150} = 0.466$$

$$p_t = 0.129$$

$$A_{st} = \frac{0.129 \times 1000 \times 150}{100} = 194 \text{ mm}^2.$$

$$\text{Minimum steel} = \frac{0.12}{100} \times 1000 \times 180 = 216 \text{ mm}^2.$$

Provide 10 mm  $\phi$  about 180 mm c/c = 436 mm<sup>2</sup> in short span and 8 mm  $\phi$  about 230 mm c/c = 217 mm<sup>2</sup> in long span.

The bars cannot be bent or curtailed because if 50% of long span bars are curtailed, the remaining bars will be less than minimum.

At top on support, provide 50% of bars of respective span to take into account any possible negative moment created due to monolithic nature of slab.

Check for development length:

$$\text{Long span } V_u = 11.25 \times 2.25 = 25.31 \text{ kN.}$$

$$M_{u1} = 0.87 \times 415 \times 217 \left( 150 - \frac{415 \times 217}{1000 \times 20} \right) \times 10^{-6}$$

$$= 11.40 \text{ kNm.}$$

$$\text{Assuming } L_0 = 8 \phi$$

$$1.3 \times \frac{11.40 \times 10^6}{25.31 \times 10^3} + 8 \phi \geq 47 \phi$$

which gives  $\phi \leq 15.01 \text{ mm} \dots\dots\dots (\text{O.K.})$

$$\text{short span } V_u = 11.25 \times 2.25 = 25.31 \text{ kN.}$$

$$M_{u1} = 0.87 \times 415 \times 436 \left( 160 - \frac{415 \times 436}{1000 \times 20} \right) \times 10^{-6}$$

$$= 23.76 \text{ kNm.}$$

$$\text{Assuming } L_0 = 8 \phi$$

$$1.3 \times \frac{23.76 \times 10^6}{25.31 \times 10^3} + 8 \phi \geq 47 \phi$$

which gives  $\phi \leq 31.3 \text{ mm} \dots\dots\dots (\text{O.K.})$

Note that the bond is usually critical along long direction.

Check for shear:

This is critical along long span

$$\text{Shear stress } \tau_v = \frac{25.31 \times 10^3}{1000 \times 150} = 0.169 \text{ N/mm}^2$$

$$\frac{100 A_s}{bd} = \frac{100 \times 217}{1000 \times 150} = 0.145$$

$$\tau_c = 0.28 \text{ N/mm}^2$$

$$k \tau_c = 0.28 \times 1.2 = 0.336 \text{ N/mm}^2 \dots\dots\dots (\text{O.K.})$$

Check for deflection:

The deflection shall be checked along short span.

$$\text{Basic } \frac{\text{span}}{d} \text{ ratio} = 20$$

$$\frac{100 A_s}{b d} = \frac{448 \times 100}{1000 \times 160} = 0.28.$$

$$\text{service stress} = 0.58 \times 415 \times \frac{435}{448} = 234 \text{ N/mm}^2$$

Note that  $A_{st,req}$  is used here.

$$\text{Modification factor} = 1.5$$

$$\text{Permissible } \frac{\text{span}}{d} \text{ ratio} = 20 \times 1.5 = 30$$

$$\text{actual } \frac{\text{span}}{d} \text{ ratio} = \frac{4480}{160} = 28 \dots\dots\dots (\text{O.K.})$$

Check for cracking:

Maximum spacing permitted for short span steel

$$= 3 \times 160 = 480 \text{ or } 300 \text{ mm, i.e., } 300 \text{ mm}$$

Spacing provided = 180 mm  $\dots\dots\dots$  (O.K.)

Maximum spacing permitted for long span steel =  $3 \times 150 = 450 \text{ mm.}$

Spacing provided = 230 mm  $\dots\dots\dots$  (O.K.)

Sketch: The designed reinforcements of slab are shown in fig. 10-26.

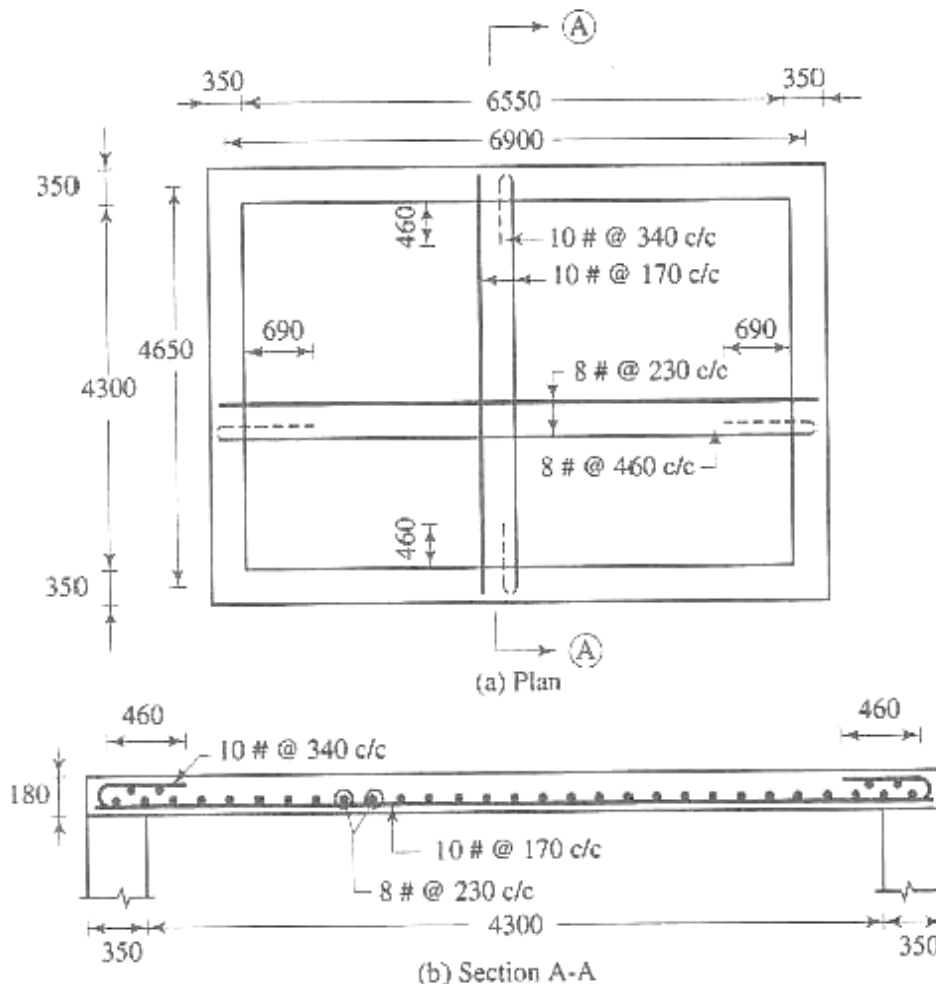

Note: It is possible to bend short span reinforcement alternately. Rework the problem

## **CHAPTER – 8**

### **DESIGN OF AXIALLY LOADED COLUMNS AND FOOTINGS**

#### **Introduction –**

A column may be defined as an element used primarily to support axial compressive loads and with a height of at least three times its least lateral dimension. All columns are subjected to some moment which may be due to accidental eccentricity or due to end restraint imposed by monolithically placed beams or slabs. The strength of a column depends on the strength of the materials, shape and size of the cross-section, length and the degree of the positional and directional restraint at its end.

A column may be classified as short or long column depending on its effective slenderness ratio. The ratio of effective column length to least lateral dimension is referred to as effective slenderness ratio. A short column has a maximum slenderness ratio of 12. Its design is based on the strength of the materials and the applied loads. A long column has a slenderness ratio greater than 12. Its design is based on the strength of the materials and the applied loads. A long column has a slenderness ratio greater than 12. However, maximum slenderness ratio of a column should not exceed 0. A long column is designed to resist the applied loads plus additional bending moments induced due to its tendency to buckle.

#### **ASSUMPTIONS -**

The following assumptions are made for the limit state of collapse in compression.

1. Plane sections normal to the axis remain plane after bending.
2. The relationship between stress-strain distribution in concrete is assumed to be parabolic. The maximum compressive stress is equal to  $0.67 \delta_{ck} / 1.5$  or  $0.446 \delta_{ck}$ .
3. The tensile strength of concrete is ignored.
4. The stresses in reinforcement are derived from the representative stress-strain curve for the type of steel used.
5. The maximum compressive strain in concrete in axial compression is taken as 0.002.
6. The maximum compression strain at the highly compressed extreme fibre in concrete subjected to axial compression and bending, but when there is no tension on the section, is taken as 0.0035 minus 0.75 times the strain at the least compressed extreme fibre.
7. The maximum compressive strain at the highly compressed extreme fibre in concrete subjected to axial compression and bending, when part of the section is in tension, is taken as 0.0035. In the limiting case when the neutral axis lies along one edge of the section, the strain varies from 0.0035 at the highly compressed edge to zero at the opposite edge.



### The types of failures to the columns –

Columns, when centrally loaded, fail in one of the three following modes, depending on the slenderness ratio.

Fig.

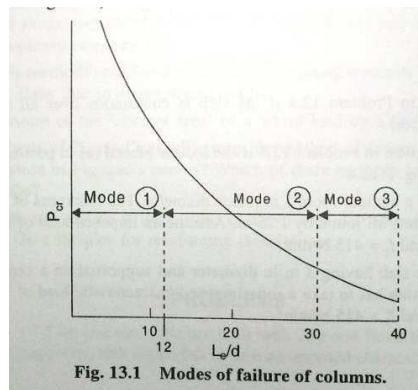

#### Mode :1 Pure compression failure

\_\_\_\_\_ The columns fail under axial loads without undergoing any lateral deformation. Steel and concrete reach the yield stress values at failure. The collapse is due to material failure.

#### Mode :2 Combined compression and bending failure

Short columns can be subjected to direct load ( $P$ ) and moment ( $M$ ). Slender columns even when loaded axially undergo deflection along their length as beam columns, and these deflections produce additional moments in the columns. When material failure is reached under the combined action of these direct loads and bending moment. It is called combined compression and bending failure.

#### Mode : 3 Failure by elastic instability

Very long columns can become unstable even under small loads well before the material reaches yield stresses. Under such cases the member fails by lateral 'elastic buckling'.

Failure by third mode is unacceptable in practical construction. R.C.C. members that may fail by this type of failure is prevented by the code provision that columns beyond a specified slenderness should not be allowed in structure.

### Braced and unbraced columns :

The columns in a building are classified as braced or unbraced according to the method applied to provide the lateral stability of the building.

- (1) **Braced column** : In braced frames, the lateral loads like wind, earthquake etc. are resisted by some special arrangements like shear walls, bracings or special supports. In other words, the sideways or joint translation is not possible in such columns. Sideways or joint translation means that one or both the ends of a column can move laterally with respect to each other. The columns occurring in braced buildings are called braced columns.

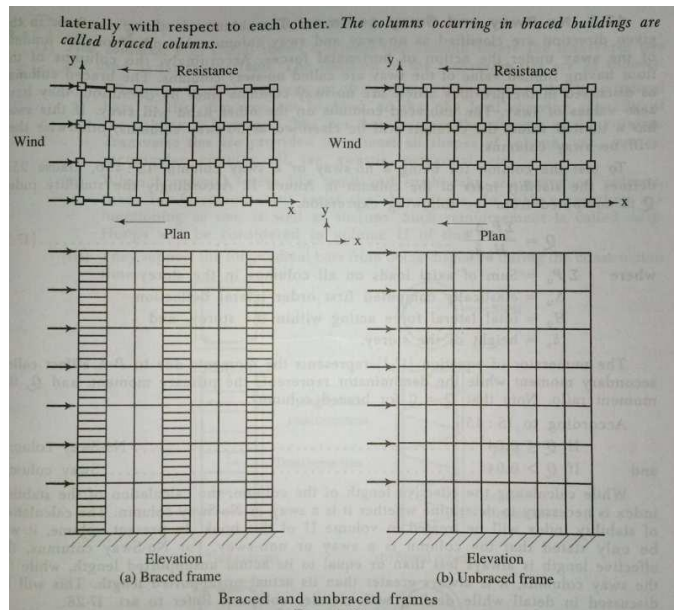

(2) **Unbraced columns :** A unbraced frames no special bracing systems are provided to resist horizontal forces. In other words the sidesway or joint translation do occur in such columns. The columns shall have to be designed to resist the lateral loads. The column those occur in the buildings where the resistance to lateral loads is provided by the bending in the columns and beams in that plane are called unbraced columns.

**Effective length of columns :**

The unsupported length or height of a column ( $L_0$ ) is generally taken as the clear height of the columns. It is defined in IS 456, clause 25.1.3 for various cases of constructions. The effective length of column is different from unsupported length. Effective length ( $L_e$ ) is dependent on the bracing and end conditions. It should be noted that for braced columns the effective column height is less than the clear height between restraints, whereas for unbraced and partially braced columns the effective height is greater than the clear height.

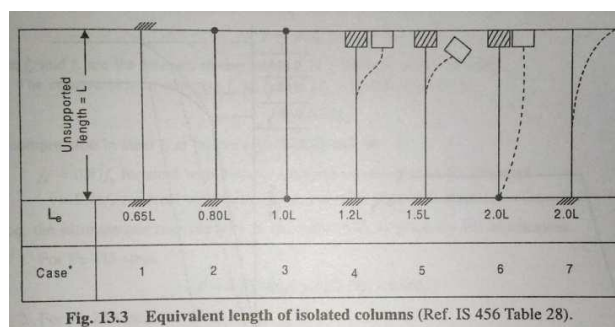

**Design formula for Short column –**

A rectangular column section bearing pure axial load. The design stress in mild steel at strain of 0.002 is  $0.87 f_y$ , however for , HYSD bars it is not so. The stresses corresponding to 0.002 strain in HYSD bars are as follows.

$F_e 415$	$0.79 f_y$
$F_e 500$	$0.75 f_y$

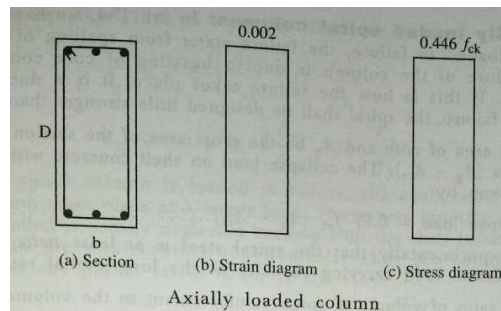

The code adopts the critical value of  $0.75 f_y$  for all grades of steel for finding out the pure axial load carrying capacity of the column. Accordingly

$$P_{uz} = 0.446 f_{ck} A_c + 0.75 f_y A_{cc}$$

This is approximated as

$$P_{uz} = 0.446 f_{ck} A_c + 0.75 f_y A_{cc}$$

$P_{uz}$  = Pure ultimate axial load carrying capacity of column.

$f_{ck}$  = Characteristic compressive strength of concrete.

$f_y$  = Characteristic strength of reinforcement.

$A_c$  = Area of concrete in column section.

$A_{cc}$  = Area of reinforcement in column section.

Axially loaded practical columns are subjected to moments due to minimum eccentricity . thus all the columns , even if the design load is axial, shall be designed for moments also.

The code simplifies the work for the columns in which minimum eccentricity  $e_{Nin} \leq 0.05 D$ . Thus , when  $e_{Nin} \leq 0.05 D$  , the above equation is modified as

$$P_u = 0.4 f_{ck} A_c + 0.67 f_y A_{cc} \dots\dots\dots$$

It can be seen that , the load carrying capacity of the column is reduced by about 10 percent when  $e_{Nin} \leq 0.05 D$ . however if  $e_{Nin} \leq 0.05 D$  , the column shall be designed for moment also.

The above equation can written as –

$$P_u = 0.4 f_{ck} \left( A_g - \frac{P E_g}{100} \right) + 0.67 f_y \frac{P E_g}{100}$$

Where  $A_g$  = Gross area of cross section

$P$  = Percentage of reinforcement.

Dividing both sides by  $A_g$

$$\frac{P_u}{A_g} = 0.4 f_{ck} \left(1 - \frac{P}{100}\right) + 0.67 f_y \frac{P}{100}$$

$$= 0.4 f_{ck} \frac{P}{100} (0.67 f_y - 0.4 f_{ck}) \dots$$

The compression in steel  $f_c$  at failure ( $\epsilon_c = 0.002$ ) will be

$f_c = 0.87 f_y$  for steel with bilinear stress-strain curve as in Fe 250 steel.

$= 0.75 f_y$  for steel with stress-strain curve as in Fe 415 steel.

Hence, the ultimate carrying capacity of the column  $e_u$  is given by the expression

$$1. \text{ For Fe 415 steel, } P = A_c (0.45 f_{ck}) + A_c (0.75 f_y - 0.45 f_{ck})$$

$$2. \text{ For Fe 250 steel, } P = A_c (0.45 f_{ck}) + A_c (0.87 f_y - 0.45 f_{ck})$$

However it is never possible to apply the load centrally on a column. Accidental eccentricities are bound to happen. Indian and British codes allow an accidental eccentricity of 5 percent of the lateral dimension of the column in the plane of bending ( $0.05 D$ ) in the strength formula itself. For this purpose the ultimate load  $e_u$  for Fe 415 steel reduces to

$$P_u = 0.9 (0.45 f_{ck} A_c + 0.75 f_y A_c)$$

$$P_w = 0.4 f_{ck} A_c + 0.67 f_y A_c \quad \text{as given in IS 456, clause 38.3}$$

With Fe 250 steel the corresponding expression will be

$$P_u = 0.4 f_{ck} A_c + 0.75 f_y A_c$$

It should be clearly noted these formula already take into account a maximum accidental eccentricity of ( $0.05 D$ ) or ( $0.05b$ ) in these columns.

### **Check for Minimum Eccentricity**

Minimum eccentricities are caused by imperfections in construction, inaccuracy in loading etc. The BS code 8110 (1985) Clause 3.8.2.4 assumes that its value will be equal to  $0.05 D$ , but not more than 20mm.

IS 456, Clause 25.4 gives an expression for the possible minimum eccentricity as  $e_{\text{Min}} = \frac{L_0}{500} + \frac{D}{30}$  but not less than 20mm.

Where  $L_0$  = the unsupported length

$D$  = lateral dimensions in the plane of bending.

For sections other than rectangular, the Explanatory handbook SP 24 recommends a value of  $L_e / 300$ , where  $L_e$  is the effective length of the column.

Thus for example, for a column  $600 \times 450$  of unsupported height 3 m, considering the long direction according to IS formula,

$$e_{\text{Min}} = \frac{L_0}{500} + \frac{D}{30} = \frac{3000}{500} + \frac{600}{30} = 26\text{mm.}$$

As 26mm is greater than the minimum specified 20mm, use  $e_{Nin} = 26\text{mm}$ . then  $\frac{e_{Nin}}{D} = 26/600 = 0.043$

Considering the short direction, we have

$$e_{Nin} = 3000/500 + 450/30 = 21\text{mm} > 20\text{mm}.$$

Hence  $\frac{e}{b} = 21/450 = 0.047$ .

Both these values are less than the specified ratio of 0.05, and hence the simple column formula is applicable to the above column. If the eccentricities are more, then the column has to be designed as subjected to direct load P and moment Pe.

### **Minimum Longitudinal and Transverse reinforcement –**

The reinforcement requirements are set out in clause 26.5.3 of IS 456.

#### **1. Longitudinal Reinforcement:**

- (i) The cross sectional area of longitudinal reinforcement shall be not less than 0.8 percent of gross cross sectional area of the column.

The minimum area of the reinforcement is specified to avoid the sudden non-ductile failure of the column, to resist creep and shrinkage and to provide some bending strength to the column.

- (ii) In any column that has a larger cross sectional area than that required to support the load, the minimum percentage of steel should be based upon the area of concrete required to resist the direct stress and not upon the actual area.

Because of the architectural or the other reasons, sometimes the columns are made larger in section than that required to resist the load. In such a case, according to this criteria, the minimum percentage of steel is based on concrete area required to resist the direct load. A concrete pedestal used to transfer the load from steel stanchion to the foundation in an industrial building is a typical example for this case. In this case, the size of the pedestal is governed by the size of the base plate under the steel column.

- (iii) The cross sectional area of longitudinal reinforcement shall be not more than 6 percent of the gross cross sectional area of the column.

The use of 6percent reinforcement may involve practical difficulties in placing and compacting of concrete, hence lower percentage is recommended where bars from the columns below have to be lapped with those in the column under consideration, the percentage of steel usually should not exceed 4 percent. for the column with more than 4 percent steel, the laps may be staggered.

- (iv) The minimum number of longitudinal bars provided in a column shall be four in rectangular columns and six in circular columns.

- (v) The bar shall not be less than 12 mm in diameter.

- (vi) A reinforced concrete column having helical reinforcement shall have at least six bars of longitudinal reinforcement within the helical reinforcement.

- (vii) In a helical reinforced column , the longitudinal bars shall be in contact with the helical reinforcement and equidistant around its inner circumference.
- (viii) Spacing of longitudinal bars measured along the periphery of the column shall not exceed 300 mm. this is a cracking requirement.
- (ix) In case of the pedestals in which the longitudinal reinforcement is not taken into account in strength calculation, nominal reinforcement not less than 0.15 percent of the cross sectional area shall be provided.

**(2) Transverse Reinforcement:**

- (i) General : a reinforcement concrete compression member shall have transverse or helical reinforcement so disposed that every longitudinal bar nearest to the compression face has effective lateral support against bulking subject to provisions in (b). The effective lateral support is given by transverse reinforcement either in the form of circular rings capable of taking up circumferential tension or by polygonal links (lateral ties) with internal angles not exceeding 135 degree. The ends of the transverse reinforcement shall be properly anchored.
- (ii) Arrangement of transverse reinforcement :
  - (a) If the longitudinal bars are not spaced more than 75mm on either side, transverse reinforcement need only to go round the corner and alternate bars for the purpose of providing effective lateral supports.
  - (b) If the longitudinal bars spaced at a distance of not exceeding 48 times the diameter of the tie are effectively tied in two directions, additional longitudinal bars in between these bars need to be tied in one direction by open ties.
  - (c) Where the longitudinal reinforcing bars in a compression member are placed in more than one row, effective lateral support to the longitudinal bars in the inner rows may be assumed to have been provided if-
    - (1) Transverse reinforcement is provided for outer most row in accordance with (b) and
    - (2) No bar of the inner row is closer to the nearest compression face than three times the diameter of the largest bar in the inner row.
  - (d) Where the longitudinal bars in a compression member are grouped and each group adequately tied transverse reinforcement in accordance with the above requirements, the transverse reinforcement for the compression member as a whole may be provided on the assumption that each group is a single longitudinal bar for purpose of determining the pitch and diameter of the transverse reinforcement in accordance with above requirements. The diameter of such transverse reinforcement need not, however exceed 20mm.
- (iii) Pitch and diameter of lateral tie :

- (a) Pitch : the pitch of transverse reinforcement shall be not more than the least of the following distances:
- (1) The least lateral dimension of the compression member.
  - (2) Sixteen times the smallest diameter of the longitudinal reinforcement bar to be tied.
  - (3) 300mm.
- (b) Diameter : the diameter of the polygonal links or ties shall be not less than one fourth of the diameter of the largest longitudinal bar and in no case less than 6 mm.
- (iv) Helical reinforcement :
- (a) Pitch : Helical reinforcement shall be of regular formation with the turns of the helix spaced evenly and its ends shall be anchored properly by providing one and a half extra turns of the spiral bar. Where an increase load on the column on the strength of the helical reinforcement is allowed for, the pitch of helical turns shall be not more than 75 mm, nor more than one-sixth of the core diameter of the column, nor less than 25mm, nor less than there times the diameter of the steel bar forming the helix.
  - (b) Diameter : the diameter of the helical reinforcement shall be as per lateral ties.
- (v) Cover : the longitudinal reinforcing bar in a column shall have concrete cover, not less than 40mm, nor less than the diameter of such bar. This requirements gives a fire protection of 0.5 h to 4h (h = hour) and is suitable for moderate exposure assuming a maximum of 10 mm diameter tie. However the cover to the ties may be governed by exposure conditions. In the case of columns the minimum dimensions of 200 mm or under, whose reinforcing bars do not exceed 12mm, a cover of 25mm may be used.

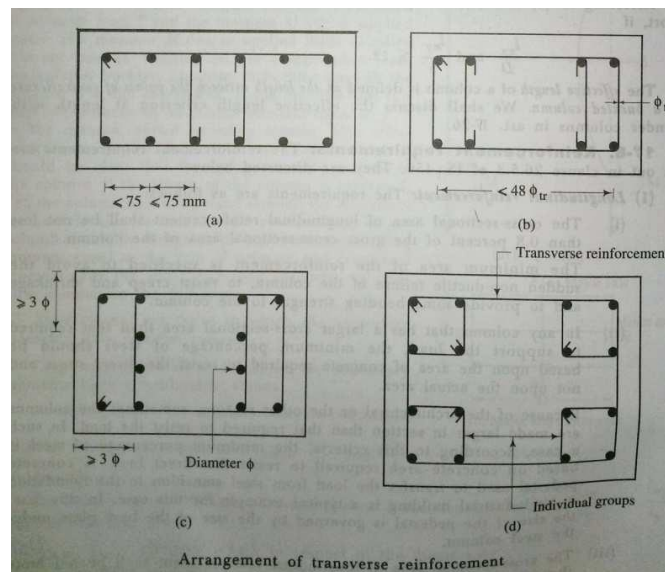

**Design of short column by IS 456 and SP 16 –**

Charts 24 to 26 of the IS publication design aids SP 16 can be used for routine office design of short columns. These charts are made from the column formula

$$P_u = 0.4 f_{ck} A_c + 0.67 f_y A_{sc}$$

$A_g$  = area of cross section

$$P = \text{percentage of steel} = 100 \frac{A_{sc}}{A_g}$$

The area of steel and concrete are given by

$$A_c = \frac{P A_g}{100}$$

$$A_{sc} = A_g - A_c = A_g \left(1 - \frac{P}{100}\right)$$

Rewriting the equation with above quantities, we obtain

$$\frac{P_u}{A_g} = 0.4 f_{ck} \left(1 - \frac{P}{100}\right) + 0.67 f_y \frac{P}{100}$$

$$P_u = \left[0.4 f_{ck} \frac{P}{100} (0.67 f_y - 0.4 f_{ck})\right] A_g$$



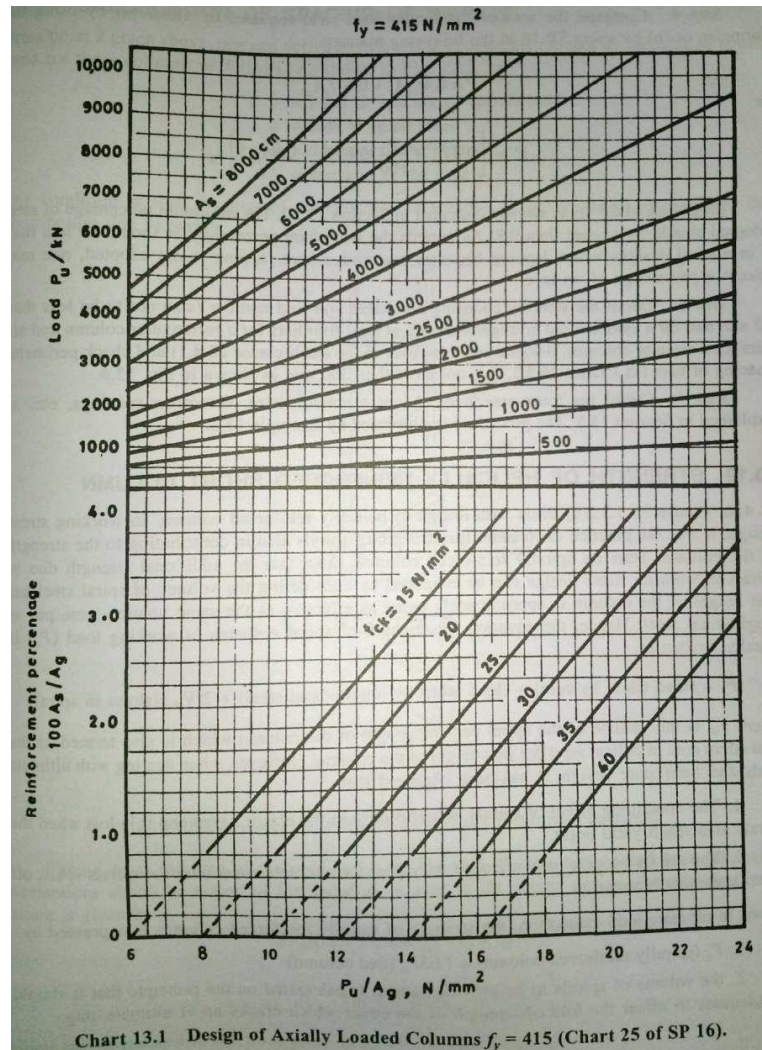

Chart 24 to 26 of SP 16 have been prepared from these formula for Fe 250 , Fe 415 and Fe 500 and  $f_{ck} = 15, 20, 30, 35, \text{ and } 40$ .

To use design chart , choose the value of the factored design load  $P_u$  , and proceed horizontally till the  $A_g$  corresponding to the size of the column selected is reached. The value of percentage of steel required for the adopted value of  $f_{ck}$  is read off from the lower half of chart 13.1.

#### **Procedure for design of centrally loaded short column:**

The step-by-step procedure for design of a centrally loaded column can be arranged as follows:

Step 1 : compute the factored load on the column.

Step 2 : Choose a suitable size for the column, depending on the size of the beam that has to be placed on it and the architectural requirements. Usually the beams are accommodated inside the column. Check also the minimum eccentricity.

Step 3: Determine the effective length and slenderness of the column about the principal axes. If it is less than 12, it can be considered as a short column. If it is 12 or more, it is to be designed as a long column.

Step 4 : compute the area of the longitudinal steel required by either (a) by using the formula or (b) by using SP 16 in the following manner.

$$P_u = 0.4 f_{ck} A_c + 0.67 f_y A_{sc}$$

or 
$$P_u = [ 0.4 f_{ck} \frac{P}{100} ( 0.67 f_y - 0.4 f_{ck} ) ] A_g$$

The minimum percentage of steel adopted should be greater than 0.8. As regards the maximum percentage, it should be less than 4 in normal designs where lapping becomes essential. Where lapping is not adopted, one may accept a percentage of up to 6.

Step 5: Detail the steel by choosing a suitable size and number (size not to be less than 12mm and for a symmetrical arrangement with at least four bars for a rectangular column and six bars for a circular column). Adopt a suitable cover to the steel ( clause 26.4.1) and check perimeter spacing of bars (IS clause 26.5.3.1) is not more than 300mm.

Step 6: Detail the transverse steel. Adopt a suitable size, determine spacings, etc.

**Strength of helically reinforced short column:**

IS 456, clause 26.5.3.2(d) deals with design of helically reinforced column. In working stress design, it is practice to consider the strength of spirals also in contributing to the strength of the column. Tests on spirally reinforced columns show that the additional strength due to spirals in working stress design can be estimated by considering the volume of spiral steel per unit height of the column is approximately twice as effective as the same volume were put as longitudinal steel. Hence the equation for strength of spiral columns in working load ( $P_c$ ) is usually written as

$$P_c = ( \text{Load taken by core} ) + ( \text{load taken by longitudinal steel} ) + 2 ( V_{ch} ) ( \text{stress in spiral} )$$

Where  $V_{ch}$  is the volume of the spiral per unit length of the column which is also termed as the equivalent area of helical steel per unit height of the column. However when dealing with ultimate loads and limit state design, it has been observed that

1. The containing effect of spirals is useful only in the elastic stage and it is lost when the spirals also reach yield point.
2. The spirals become fully effective only after the concrete cover over the spirals spalls off after excessive deformation.

Hence in ultimate load estimation, the strength of spirally reinforced columns is expressed by

1.  $P_u(\text{spirally reinforced column}) = 1.05 P_u(\text{tied column})$
2. The volume of spirals to be provided which is calculated on the principle that it should be adequate to offset the loss of strength of the cover which cracks up at ultimate stage.

**Calculation of spacing of spirals:**

$S$  = Pitch or spacing of spirals used.

$a$  = area of spiral steel .

$D$  = diameter of the column.

$D_k$  = diameter of the core.

The condition is that the loss of strength due to spalling of cover should be equal to the contribution due to spirals.

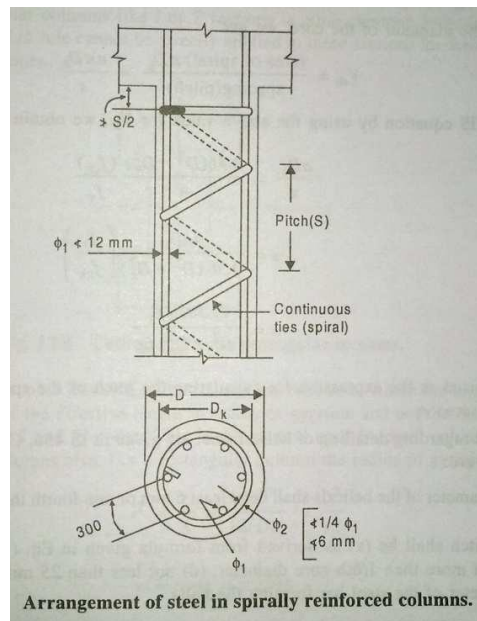

Taking  $A_k$  as the area of the core and  $A_g$  as the area of cross section and using the same assumption about the action of the spiral as is used in the elastic design, the relationship at failure is given by

$$2V_{ch}(0.87f_y) = 0.63 f_{ck} (A_g - A_k)$$

$$V_{ch} = 0.36 (A_g - A_k) \left( \frac{f_{ck}}{f_y} \right)$$

Which can be reduced to the form given in IS 456, clause 38.4.1 as

$$\frac{V_{ch}}{A_k} = 0.36 \left( \frac{A_g}{A_k} - 1 \right) \left( \frac{f_{ck}}{f_y} \right)$$

Where  $A_g$  = gross area of section

$A_k$  = area of core.

This expression gives the ratio of the volume of the helical reinforcement required for the volume of the core per unit height of the column.

Simplifying this expression further, one can write

$$V_{ch} = (\text{Volume of the spiral in one ring}) \times (\text{No. Of rings per unit length})$$

Taking  $D_k$  as the diameter of the core , we get

$$V_{ch} = \frac{(\text{area of spirals}) n D_k}{\text{Spacing (pitch)}} = \frac{a n D_k}{c}$$

Rewriting the IS equation by using the above value for  $V_{ch}$ , we get

$$\frac{aD_k}{c} = \frac{0.36(D^2 - D_k^2)}{4} \frac{f_{ck}}{f_y}$$

$$S = \frac{4aD_k}{0.36(D^2 - D_k^2)} \frac{f_y}{f_{ck}}$$

$$S = \frac{11.1aD_k f_y}{f_{ck}(D^2 - D_k^2)} \dots\dots\dots(1)$$

Which can be used as the expression for calculating the pitch of the spirals for a given steel of cross section area a.

The rules regarding detailing of helical steel are given IS 456, clause 26.5.3.2. the main considerations are:

1. The diameter of the helicals shall be at least 6mm or one fourth the diameter of longitudinal steel.
2. The pitch shall be (a) as derived from formula equation (1) (b) not more than 75mm, (c) not more than 1/6<sup>th</sup> core diameter , (d) not less than 25mm, (e) not less than three times the diameter of the steel bar forming the helix.

If the diameter and the pitch of the spirals do not comply with the above rules, the strength is to be taken as only that of a tied column of similar dimension.

**Problem 1:**

A column of 400 x400mm has an unsupported length of 7m and effective length of 4.5 m. Can it be designed as a short column under axial compression , if the load placed centrally on it?

**Solution:**

Step 1: Slenderness ratio consideration

$$\frac{L_e}{D} = 4500 / 400 = 11.25 \quad (\text{IS456 Cl.25.1.2})$$

As columns with slenderness less than 12 can be considered as short , the column is short.

Step 2: Eccentricity considerations

$$e_{Nin} = \frac{L_0}{500} + \frac{D}{30} \text{ not less than } 20\text{mm.} \quad (\text{IS 456 Cl . 25.4})$$

$$= 7000/ 500 + 400/30$$

$$= 14 + 13.3$$

$$27.3 \text{ mm is greater than } 20\text{mm.} \quad \text{Adopt } 27.3\text{mm}$$

The eccentricity for which short column formula is applicable is  $D/20$

$$D/20 = 400/20 = 20\text{mm} \quad (\text{IS 456 Cl.39.3})$$

$$e_{Nin} > D/20$$

Hence formula for axial load is not applicable.

Column should be designed as subject to axial load and moment due to  $e_{Nin}$ .

$$(M = P e_{Nin})$$

**Problem – 2**

Design an axially loaded tied column 400 x 400 mm pinned at both ends with an unsupported length of 3m for carrying a factored load of 2300 KN. Use grade 20 concrete and Fe 415 steel.

**Solution:**

Step 1: Factored load on column

$$P_u = 2300\text{KN}$$

Step 2: Size of column and check  $e_{Nin}$  (IS 456 Cl. 25.4)

Size of column = 400 x 400,  $D/20 = 20\text{mm}$

$$e_{Nin} = \frac{L_0}{500} + \frac{D}{30} = 3000/500 + 400/30 = 19.33 < 20\text{mm}$$

$e_{Nin}$  less than  $D/20$  is assumed in the formula. Hence short column formula for axial load can be used.

Step 3: Calculation of slenderness (IS456 Cl. 25.1.2)

$$L_e = 1.0L = 3000\text{mm}$$

$$\frac{L_e}{b} = 3000/400 = 7.5 < 12$$

Step 4: Find area of steel and check percentage

$$(a) \text{ By formula, } P_u = 0.4 f_{ck} A_c + 0.67 f_y A_{sc} \quad (\text{IS 456 Cl. 39.3})$$

$$2300 \times 10^3 = 0.4 \times 20 \times (400^2 - A_c) + 0.67 \times 415 \times A_c$$

$$A_c = 3777 \text{ mm}^2, P = 3777 / 400^2 \times 100 = 2.36\%$$

This is more than 0.8% and less than 6%. hence o.k

$$(b) \text{ By SP 16, } A_g = 1600 \text{ cm}^2, P = 2300 \text{ KN. } P = 2.4\% \quad (\text{SP 16 chart 25})$$

$$A_c = (2.4 \times 400 \times 400) / 100 = 3840 \text{ mm}^2 \quad (\text{Use 8T -25 / 3927 mm}^2)$$

Step 5 : Detail the longitudinal steel

$$\text{Use cover} = 40\text{mm} \quad (\text{Cl. 26.4.2.1})$$

$$\text{Steel spacing} = (400 - 40 - 40 - 25) / 2 = 147.5$$

$$\text{Clear spacing between bars} = 147.5 - 25 = 122.5 < 300 \quad (\text{Cl.26.5.3.1 g})$$

Step 6: Design transverse steel

Diameter of links : not less than  $25/4$  or 6mm.

Use 10mm

Spacing least of [ Cl. 26.5.3.2 (c)]

(a) Dimension of column = 400mm

(b) 16 times  $\emptyset$  of long steel =  $16 \times 25 = 400\text{mm}$

(c) 300 mm adopt 300mm.

Use Fe250 steel for ties.

$$(a) S = \frac{11.1 a D_k f_y}{f_{ck} (D^2 - D_k^2)} = (11.1 \times 28 \times 400 \times 145) / (57600 \times 30)$$

$$= 30\text{mm} \quad \text{Cl. 39.4.1}$$

- (b) Spacing not more than 75mm
  - (c) Spacing not more than  $320 / 6 = 53.3\text{mm}$
  - (d) Spacing not less than 25
  - (e) Spacing not less than  $6 \times 3 = 18\text{mm}$
- Choose 30mm spacing.

**(Design helically reinforced columns)**

**Problem 1 :**

Design a circular pin ended column 400 mm dia and helically reinforced , with an unsupported length of 4.5 m to carry a factored load of 900 KN. Assume M30 concrete and Fe 415 steel.

Solution:

Step 1: Factored load,  $P_u = 900 \text{ Kn}$ .

Step 2: Size of column  $D = 400\text{mm}$ , cover = 40mm

$$D_{\text{core}} = 320\text{mm}$$

$$D/20 = 400/20 = 20\text{mm}.$$

$$e_{\text{min}} = \frac{L_0}{500} + \frac{400}{30} = \frac{4500}{500} + \frac{400}{30} = 22.3\text{mm} > 20\text{mm}.$$

As  $e_{\text{min}} > D/20$ , theoretically short column formula for centrally loaded column is not applicable. However the column is designed as centrally loaded, as the moment to be considered is small.

Step 3: Slenderness of column

$$\frac{L_e}{D} = 4500/40 = 11.25 < 12. \text{ (centrally loaded Short Column)}$$

Step 4: Area of longitudinal steel

$$P_u = 1.05 (0.4 f_{ck} A_c + 0.67 f_y A_{sc}) \quad (\text{IS456 Cl. 39.4})$$

$$A_c = n \times 400^2 / 4 = 125.6 \times 10^3 \text{ mm}^2, \quad P \frac{900}{1.05} = \frac{900}{1.05} = 857 \text{ KN}.$$

$$857 \times 10^3 = [0.4 \times 30 \times (125600 - A_c) + 0.67 \times 415 A_c]$$

$$= 1507 \times 10^3 + A_c (278 - 12)$$

Concrete itself can carry more than the required load.

Hence provide minimum steel.

$$A_{c(\text{min})} = 0.8\% \text{ ( of area required to carry P )} \quad \text{IS 456 Cl 26.5.3.1 (a) (b)}$$

$$A_c \text{ to resist given P} = \frac{900 \times 10^3}{1.05 \times 0.4 \times 30} = 71428\text{mm}^2$$

$$A_{c(\text{min})} = \frac{0.8}{100} \times (71428) = 571.4 \text{ mm}^2.$$

Provide 6 nos. Of 12mm bars giving area 678 mm<sup>2</sup> as minimum number of bars allowed is 6 nos.

Step 5: Design Spirals CL.26.5.3.1(c)

Choose 6mm,  $a = 28 \text{ mm}^2$  (area) ,  $s =$  pitch.

Detailing at junctions with reinforcement footing –

